

MiTek, Inc.
400 Sunrise Ave., Suite 270
Roseville, CA 95661
916.755.3571

Re: J1183948F2

NW Eastside Builders LLC

The truss drawing(s) referenced below have been prepared by MiTek USA, Inc. under my direct supervision based on the parameters provided by The Truss Company (Sumner, WA).

Pages or sheets covered by this seal: R91075006 thru R91075032

My license renewal date for the state of Washington is September 28, 2027.



November 4, 2025

Zhao, Xiaoming

IMPORTANT NOTE: The seal on these truss component designs is a certification that the engineer named is licensed in the jurisdiction(s) identified and that the designs comply with ANSI/TPI 1. These designs are based upon parameters shown (e.g., loads, supports, dimensions, shapes and design codes), which were given to MiTek or TRENCO. Any project specific information included is for MiTek's or TRENCO's customers file reference purpose only, and was not taken into account in the preparation of these designs. MiTek or TRENCO has not independently verified the applicability of the design parameters or the designs for any particular building. Before use, the building designer should verify applicability of design parameters and properly incorporate these designs into the overall building design per ANSI/TPI 1, Chapter 2.

Job J1183948F2	Truss ZF03	Truss Type Floor Blocking	Qty 1	Ply 1	NW Eastside Builders LLC Job Reference (optional)	R91075006
-------------------	---------------	------------------------------	----------	----------	--	-----------

The Truss Company (Sumner, WA), Sumner, WA - 98390,

Run: 25.30 S Oct 2 2025 Print: 25.3.0 S Oct 2 2025 MiTek Industries, Inc. Mon Nov 03 18:02:00
ID:j9VRCbU7Nd?Sh?2GTOzDoaz87XM-RfC?PsB70Hq3NSgPqnL8w3uITXbGKWrCDoi7J4zJC?f

Page: 1

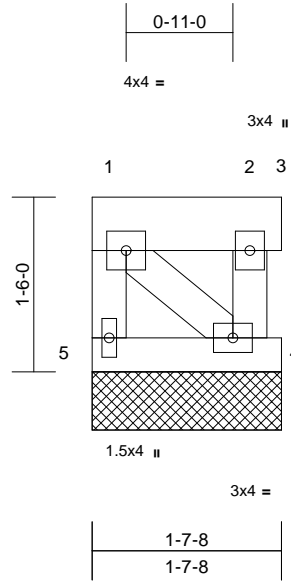

Scale = 1:19.8

Loading	(psf)	Spacing	2-0-0	CSI	DEFL	in	(loc)	l/defl	L/d	PLATES	GRIP	
TCLL	40.0	Plate Grip DOL	1.00	TC	0.01	Vert(LL)	n/a	-	n/a	999	MT20	185/148
TCDL	10.0	Lumber DOL	1.00	BC	0.00	Vert(TL)	n/a	-	n/a	999		
BCLL	0.0	Rep Stress Incr	YES	WB	0.00	Horiz(TL)	0.00	3	n/a	n/a		
BCDL	5.0	Code	IRC2021/TPI2014	Matrix-P							Weight: 9 lb	FT = 11%

LUMBER

TOP CHORD 2x6 DF SS
BOT CHORD 2x4 HF-N No.1/No.2
WEBS 2x4 DF Stud

BRACING

TOP CHORD Structural wood sheathing directly applied or 1-7-8 oc purlins, except end verticals.
BOT CHORD Rigid ceiling directly applied or 10-0-0 oc bracing.

REACTIONS (size) 3=1-7-8, 4=1-7-8, 5=1-7-8
Max Grav 3=26 (LC 1), 4=65 (LC 1), 5=69 (LC 1)

FORCES (lb) - Maximum Compression/Maximum Tension

TOP CHORD 1-5=-63/0, 2-4=-59/0, 1-2=0/0, 2-3=0/0
BOT CHORD 4-5=0/0
WEBS 1-4=0/0

NOTES

- Gable requires continuous bottom chord bearing.
- Recommend 2x6 strongbacks, on edge, spaced at 10-00-00 oc and fastened to each truss with 3-10d (0.131" X 3") nails. Strongbacks to be attached to walls at their outer ends or restrained by other means.

LOAD CASE(S) Standard



November 4, 2025

WARNING - Verify design parameters and READ NOTES ON THIS AND INCLUDED MITEK REFERENCE PAGE MII-7473 rev. 1/2/2023 BEFORE USE.

Design valid for use only with MiTek® connectors. This design is based only upon parameters shown, and is for an individual building component, not a truss system. Before use, the building designer must verify the applicability of design parameters and properly incorporate this design into the overall building design. Bracing indicated is to prevent buckling of individual truss web and/or chord members only. Additional temporary and permanent bracing is always required for stability and to prevent collapse with possible personal injury and property damage. For general guidance regarding the fabrication, storage, delivery, erection and bracing of trusses and truss systems, see **ANSI/TPI1 Quality Criteria and DSB-22** available from Truss Plate Institute (www.tpinst.org) and **BCSI Building Component Safety Information** available from the Structural Building Component Association (www.sbcsccomponents.com)

MiTek®

400 Sunrise Ave., Suite 270
Roseville, CA 95661
916.755.3571 / MiTek-US.com

Job J1183948F2	Truss ZF02	Truss Type Floor Blocking	Qty 12	Ply 1	NW Eastside Builders LLC Job Reference (optional)	R91075007
-------------------	---------------	------------------------------	-----------	----------	--	-----------

The Truss Company (Sumner, WA), Sumner, WA - 98390,

Run: 25.30 S Oct 2 2025 Print: 25.3.0 S Oct 2 2025 MiTek Industries, Inc. Mon Nov 03 18:02:00
ID:j9VRCbU7Nd?Sh?2GTOzDoaz87XM-RfC?PsB70Hq3NSgPqnL8w3uITXbGKWrCDoi7J4zJC?f

Page: 1

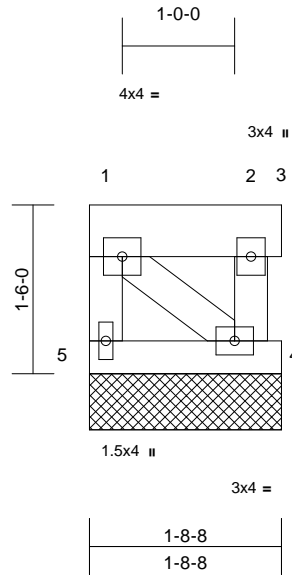

Scale = 1:20.5

Loading	(psf)	Spacing	2-0-0	CSI	DEFL	in	(loc)	l/defl	L/d	PLATES	GRIP	
TCLL	40.0	Plate Grip DOL	1.00	TC	0.01	Vert(LL)	n/a	-	n/a	999	MT20	185/148
TCDL	10.0	Lumber DOL	1.00	BC	0.00	Vert(TL)	n/a	-	n/a	999		
BCLL	0.0	Rep Stress Incr	YES	WB	0.00	Horiz(TL)	0.00	3	n/a	n/a		
BCDL	5.0	Code	IRC2021/TPI2014	Matrix-P							Weight: 9 lb	FT = 11%

LUMBER

TOP CHORD 2x6 DF SS
BOT CHORD 2x4 HF-N No.1/No.2
WEBS 2x4 DF Stud

BRACING

TOP CHORD Structural wood sheathing directly applied or 1-8-8 oc purlins, except end verticals.
BOT CHORD Rigid ceiling directly applied or 10-0-0 oc bracing.

REACTIONS (size) 3=1-8-8, 4=1-8-8, 5=1-8-8
Max Grav 3=23 (LC 1), 4=73 (LC 1), 5=73 (LC 1)

FORCES (lb) - Maximum Compression/Maximum Tension

TOP CHORD 1-5=-67/0, 2-4=-67/0, 1-2=0/0, 2-3=0/0
BOT CHORD 4-5=0/0
WEBS 1-4=0/0

NOTES

- Gable requires continuous bottom chord bearing.
- Recommend 2x6 strongbacks, on edge, spaced at 10-00-00 oc and fastened to each truss with 3-10d (0.131" X 3") nails. Strongbacks to be attached to walls at their outer ends or restrained by other means.

LOAD CASE(S) Standard



November 4, 2025

WARNING - Verify design parameters and READ NOTES ON THIS AND INCLUDED MITEK REFERENCE PAGE MII-7473 rev. 1/2/2023 BEFORE USE.

Design valid for use only with MiTek® connectors. This design is based only upon parameters shown, and is for an individual building component, not a truss system. Before use, the building designer must verify the applicability of design parameters and properly incorporate this design into the overall building design. Bracing indicated is to prevent buckling of individual truss web and/or chord members only. Additional temporary and permanent bracing is always required for stability and to prevent collapse with possible personal injury and property damage. For general guidance regarding the fabrication, storage, delivery, erection and bracing of trusses and truss systems, see **ANSI/TPI1 Quality Criteria and DSB-22** available from Truss Plate Institute (www.tpinst.org) and **BCSI Building Component Safety Information** available from the Structural Building Component Association (www.sbcsccomponents.com)

MiTek®

400 Sunrise Ave., Suite 270
Roseville, CA 95661
916.755.3571 / MiTek-US.com

Job J1183948F2	Truss ZF01	Truss Type Floor Blocking	Qty 6	Ply 1	NW Eastside Builders LLC Job Reference (optional)	R91075008
-------------------	---------------	------------------------------	----------	----------	--	-----------

The Truss Company (Sumner, WA), Sumner, WA - 98390,

Run: 25.30 S Oct 2 2025 Print: 25.3.0 S Oct 2 2025 MiTek Industries, Inc. Mon Nov 03 18:02:00
ID:j9VRCbU7Nd?Sh?2GTOzDoaz87XM-RfC?PsB70Hq3NSgPqnL8w3uITXbGKWrCDoi7J4zJC?f

Page: 1

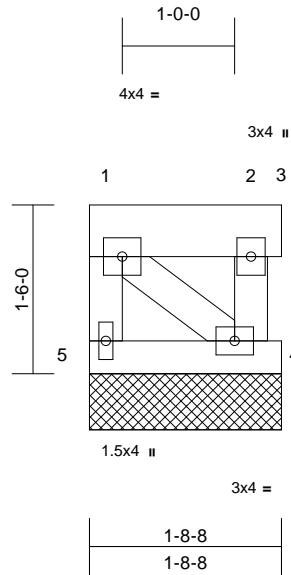

Scale = 1:20.5

Loading	(psf)	Spacing	2-0-0	CSI	DEFL	in	(loc)	l/defl	L/d	PLATES	GRIP	
TCLL	40.0	Plate Grip DOL	1.00	TC	0.01	Vert(LL)	n/a	-	n/a	999	MT20	185/148
TCDL	10.0	Lumber DOL	1.00	BC	0.00	Vert(TL)	n/a	-	n/a	999		
BCLL	0.0	Rep Stress Incr	YES	WB	0.00	Horiz(TL)	0.00	3	n/a	n/a		
BCDL	5.0	Code	IRC2021/TPI2014	Matrix-P							Weight: 9 lb	FT = 11%

LUMBER

TOP CHORD 2x6 DF SS
BOT CHORD 2x4 HF-N No.1/No.2
WEBS 2x4 DF Stud

BRACING

TOP CHORD Structural wood sheathing directly applied or 1-8-8 oc purlins, except end verticals.
BOT CHORD Rigid ceiling directly applied or 10-0-0 oc bracing.

REACTIONS (size) 3=1-8-8, 4=1-8-8, 5=1-8-8
Max Grav 3=23 (LC 1), 4=73 (LC 1), 5=73 (LC 1)

FORCES (lb) - Maximum Compression/Maximum Tension

TOP CHORD 1-5=-67/0, 2-4=-67/0, 1-2=0/0, 2-3=0/0
BOT CHORD 4-5=0/0
WEBS 1-4=0/0

NOTES

- Gable requires continuous bottom chord bearing.
- Recommend 2x6 strongbacks, on edge, spaced at 10-00-00 oc and fastened to each truss with 3-10d (0.131" X 3") nails. Strongbacks to be attached to walls at their outer ends or restrained by other means.

LOAD CASE(S) Standard



November 4, 2025

WARNING - Verify design parameters and READ NOTES ON THIS AND INCLUDED MITEK REFERENCE PAGE MII-7473 rev. 1/2/2023 BEFORE USE.

Design valid for use only with MiTek® connectors. This design is based only upon parameters shown, and is for an individual building component, not a truss system. Before use, the building designer must verify the applicability of design parameters and properly incorporate this design into the overall building design. Bracing indicated is to prevent buckling of individual truss web and/or chord members only. Additional temporary and permanent bracing is always required for stability and to prevent collapse with possible personal injury and property damage. For general guidance regarding the fabrication, storage, delivery, erection and bracing of trusses and truss systems, see **ANSI/TPI1 Quality Criteria and DSB-22** available from Truss Plate Institute (www.tpinst.org) and **BCSI Building Component Safety Information** available from the Structural Building Component Association (www.sbcscomponents.com)

MiTek®

400 Sunrise Ave., Suite 270
Roseville, CA 95661
916.755.3571 / MiTek-US.com

Job J1183948F2	Truss F24	Truss Type Floor Supported Gable	Qty 1	Ply 1	NW Eastside Builders LLC Job Reference (optional)	R91075009
-------------------	--------------	-------------------------------------	----------	----------	--	-----------

The Truss Company (Sumner, WA), Sumner, WA - 98390,

Run: 25.30 S Oct 2 2025 Print: 25.3.0 S Oct 2 2025 MiTek Industries, Inc. Mon Nov 03 18:02:00
ID:fYdCdHWNuFGAxJBfap?hu?z87XK-RfC?PsB70Hq3NSgPqnL8w3ulTXbGKWRCDoi7J4zJC?f

Page: 1

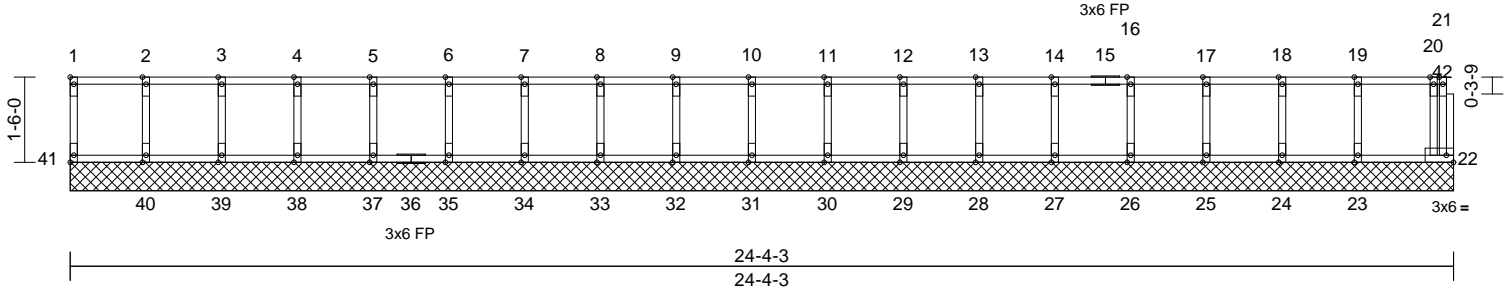

Scale = 1:40.6

Plate Offsets (X, Y): [1:Edge,0-0-12], [41:Edge,0-0-12]

Loading	(psf)	Spacing	2-0-0	CSI	DEFL	in	(loc)	l/defl	L/d	PLATES	GRIP	
TCLL	40.0	Plate Grip DOL	1.00	TC	0.08	Vert(LL)	n/a	-	n/a	999	MT20	185/148
TCDL	10.0	Lumber DOL	1.00	BC	0.02	Vert(TL)	n/a	-	n/a	999		
BCLL	0.0	Rep Stress Incr	YES	WB	0.03	Horiz(TL)	0.00	22	n/a	n/a		
BCDL	5.0	Code	IRC2021/TPI2014	Matrix-R							Weight: 96 lb	FT = 20%F, 11%E

LUMBER
TOP CHORD 2x4 HF-N No.1/No.2(flat)
BOT CHORD 2x4 HF-N No.1/No.2(flat)
WEBS 2x4 DF Stud(flat)
OTHERS 2x4 DF Stud(flat)

BRACING
TOP CHORD Structural wood sheathing directly applied or 6-0-0 oc purlins, except end verticals.
BOT CHORD Rigid ceiling directly applied or 10-0-0 oc bracing.

REACTIONS (size) 22=24-4-3, 23=24-4-3, 24=24-4-3, 25=24-4-3, 26=24-4-3, 27=24-4-3, 28=24-4-3, 29=24-4-3, 30=24-4-3, 31=24-4-3, 32=24-4-3, 33=24-4-3, 34=24-4-3, 35=24-4-3, 37=24-4-3, 38=24-4-3, 39=24-4-3, 40=24-4-3, 41=24-4-3
Max Grav 22=79 (LC 1), 23=162 (LC 1), 24=142 (LC 1), 25=148 (LC 1), 26=146 (LC 1), 27=147 (LC 1), 28=147 (LC 1), 29=147 (LC 1), 30=147 (LC 1), 31=147 (LC 1), 32=147 (LC 1), 33=147 (LC 1), 34=147 (LC 1), 35=147 (LC 1), 37=147 (LC 1), 38=146 (LC 1), 39=147 (LC 1), 40=144 (LC 1), 41=68 (LC 1)

FORCES (lb) - Maximum Compression/Maximum Tension
TOP CHORD 1-41=-58/0, 21-22=0/11, 1-2=-10/0, 2-3=-10/0, 3-4=-10/0, 4-5=-10/0, 5-6=-10/0, 6-7=-10/0, 7-8=-10/0, 8-9=-10/0, 9-10=-10/0, 10-11=-10/0, 11-12=-10/0, 12-13=-10/0, 13-14=-10/0, 14-16=-10/0, 16-17=-10/0, 17-18=-10/0, 18-19=-10/0, 19-20=-10/0, 20-21=-1/0

BOT CHORD 40-41=0/10, 39-40=0/10, 38-39=0/10, 37-38=0/10, 35-37=0/10, 34-35=0/10, 33-34=0/10, 32-33=0/10, 31-32=0/10, 30-31=0/10, 29-30=0/10, 28-29=0/10, 27-28=0/10, 26-27=0/10, 25-26=0/10, 24-25=0/10, 23-24=0/10, 22-23=0/10
WEBS 2-40=-136/0, 3-39=-133/0, 4-38=-133/0, 5-37=-133/0, 6-35=-133/0, 7-34=-133/0, 8-33=-133/0, 9-32=-133/0, 10-31=-133/0, 11-30=-133/0, 12-29=-133/0, 13-28=-133/0, 14-27=-133/0, 16-26=-133/0, 17-25=-134/0, 18-24=-130/0, 19-23=-144/0, 20-22=-86/0

NOTES
1) All plates are 1.5x4 (||) MT20 unless otherwise indicated.
2) Attach ribbon block to truss with 3-10d nails applied to flat face.
3) Gable requires continuous bottom chord bearing.
4) Truss to be fully sheathed from one face or securely braced against lateral movement (i.e. diagonal web).
5) Gable studs spaced at 1-4-0 oc.
6) Recommend 2x6 strongbacks, on edge, spaced at 10-00-00 oc and fastened to each truss with 3-10d (0.131" X 3") nails. Strongbacks to be attached to walls at their outer ends or restrained by other means.
7) CAUTION, Do not erect truss backwards.
LOAD CASE(S) Standard



November 4, 2025

WARNING - Verify design parameters and READ NOTES ON THIS AND INCLUDED MITEK REFERENCE PAGE MII-7473 rev. 1/2/2023 BEFORE USE.

Design valid for use only with MiTek® connectors. This design is based only upon parameters shown, and is for an individual building component, not a truss system. Before use, the building designer must verify the applicability of design parameters and properly incorporate this design into the overall building design. Bracing indicated is to prevent buckling of individual truss web and/or chord members only. Additional temporary and permanent bracing is always required for stability and to prevent collapse with possible personal injury and property damage. For general guidance regarding the fabrication, storage, delivery, erection and bracing of trusses and truss systems, see **ANSI/TPI1 Quality Criteria and DSB-22** available from Truss Plate Institute (www.tpinst.org) and **BCSI Building Component Safety Information** available from the Structural Building Component Association (www.sbcscomponents.com)

MiTek®

400 Sunrise Ave., Suite 270
Roseville, CA 95661
916.755.3571 / MiTek-US.com

Job J1183948F2	Truss F23	Truss Type Floor	Qty 6	Ply 1	NW Eastside Builders LLC Job Reference (optional)	R91075010
-------------------	--------------	---------------------	----------	----------	--	-----------

The Truss Company (Sumner, WA), Sumner, WA - 98390,

Run: 25.30 S Oct 2 2025 Print: 25.3.0 S Oct 2 2025 MiTek Industries, Inc. Mon Nov 03 18:02:00
ID:fYdCdHWNuFGAxJBfap?hu?z87XK-RfC?PsB70Hq3NSgPqnL8w3ulTXbGKWRCDoi7J4zJC?f

Page: 1

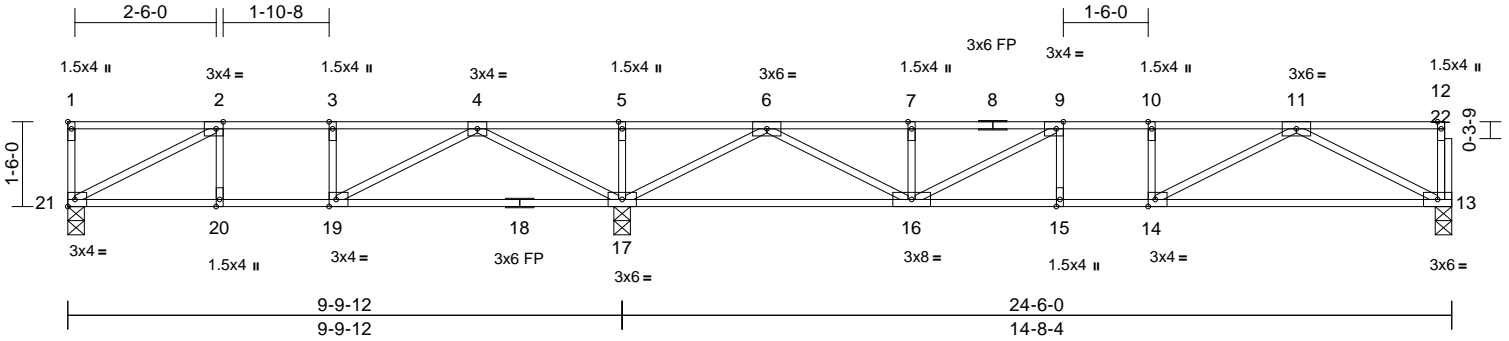

Scale = 1:40.8

Plate Offsets (X, Y): [1:Edge,0-0-12], [2:0-1-8,Edge], [9:0-1-8,Edge], [14:0-1-8,Edge], [19:0-1-8,Edge]

Loading	(psf)	Spacing	2-0-0	CSI	DEFL	in	(loc)	l/defl	L/d	PLATES	GRIP	
TCLL	40.0	Plate Grip DOL	1.00	TC	0.54	Vert(LL)	-0.12	15-16	>999	480	MT20	185/148
TCDL	10.0	Lumber DOL	1.00	BC	0.57	Vert(CT)	-0.19	13-14	>935	360		
BCLL	0.0	Rep Stress Incr	YES	WB	0.43	Horz(CT)	0.03	13	n/a	n/a		
BCDL	5.0	Code	IRC2021/TPI2014	Matrix-S							Weight: 106 lb	FT = 20%F, 11%E

LUMBER

TOP CHORD 2x4 HF-N No.1/No.2(flat)
 BOT CHORD 2x4 HF-N No.1/No.2(flat)
 WEBS 2x4 DF Stud(flat)
 OTHERS 2x4 DF Stud(flat)

BRACING

TOP CHORD Structural wood sheathing directly applied or 6-0-0 oc purlins, except end verticals.
 BOT CHORD Rigid ceiling directly applied or 6-0-0 oc bracing.

REACTIONS (size) 13=0-3-8, 17=0-3-8, 21=0-3-8
 Max Grav 13=723 (LC 7), 17=1630 (LC 8), 21=435 (LC 3)

FORCES (lb) - Maximum Compression/Maximum Tension

TOP CHORD 1-21=-126/0, 12-13=-103/0, 1-2=0/0,
 2-3=-621/60, 3-4=-621/60, 4-5=0/1295,
 5-6=0/1295, 6-7=-1503/0, 7-9=-1503/0,
 9-10=-1742/0, 10-11=-1742/0, 11-12=-5/0
 BOT CHORD 20-21=-60/621, 19-20=-60/621,
 17-19=-407/243, 16-17=-261/633,
 15-16=0/1742, 14-15=0/1742, 13-14=0/1152
 WEBS 5-17=-270/0, 4-17=-1170/0, 2-21=-701/68,
 4-19=0/653, 2-20=-43/36, 3-19=-247/0,
 6-17=-1622/0, 11-13=-1295/0, 6-16=0/1098,
 11-14=0/669, 7-16=-296/0, 10-14=-233/0,
 9-16=-578/0, 9-15=-66/73

NOTES

- 1) Unbalanced floor live loads have been considered for this design.
- 2) Attach ribbon block to truss with 3-10d nails applied to flat face.
- 3) Recommend 2x6 strongbacks, on edge, spaced at 10-00-00 oc and fastened to each truss with 3-10d (0.131" X 3") nails. Strongbacks to be attached to walls at their outer ends or restrained by other means.
- 4) CAUTION, Do not erect truss backwards.

LOAD CASE(S) Standard



November 4, 2025

WARNING - Verify design parameters and READ NOTES ON THIS AND INCLUDED MITEK REFERENCE PAGE MII-7473 rev. 1/2/2023 BEFORE USE.

Design valid for use only with MiTek® connectors. This design is based only upon parameters shown, and is for an individual building component, not a truss system. Before use, the building designer must verify the applicability of design parameters and properly incorporate this design into the overall building design. Bracing indicated is to prevent buckling of individual truss web and/or chord members only. Additional temporary and permanent bracing is always required for stability and to prevent collapse with possible personal injury and property damage. For general guidance regarding the fabrication, storage, delivery, erection and bracing of trusses and truss systems, see **ANSI/TPI1 Quality Criteria and DSB-22** available from Truss Plate Institute (www.tpinst.org) and **BCSI Building Component Safety Information** available from the Structural Building Component Association (www.sbcsccomponents.com)

MiTek®

400 Sunrise Ave., Suite 270
 Roseville, CA 95661
 916.755.3571 / MiTek-US.com

Job J1183948F2	Truss F22	Truss Type Floor	Qty 1	Ply 1	NW Eastside Builders LLC Job Reference (optional)	R91075011
-------------------	--------------	---------------------	----------	----------	--	-----------

The Truss Company (Sumner, WA), Sumner, WA - 98390,

Run: 25.30 S Oct 2 2025 Print: 25.3.0 S Oct 2 2025 MiTek Industries, Inc. Mon Nov 03 18:02:00
ID:BL3qPxV17x8JJ9dS16USLoz87XL-RfC?PsB70Hq3NSgPqnL8w3uITXbGKwRCDoi7J4zJC?f

Page: 1

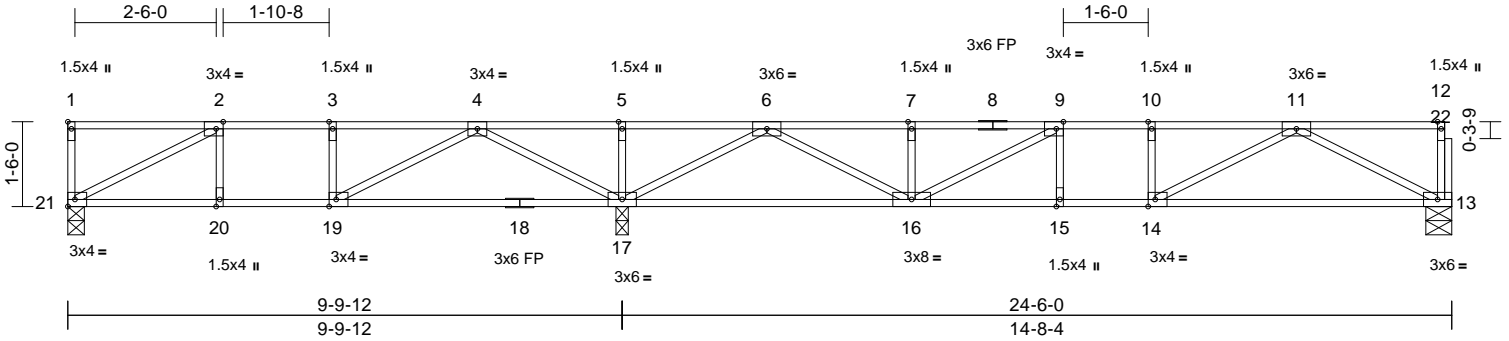

Scale = 1:40.8

Plate Offsets (X, Y): [1:Edge,0-0-12], [2:0-1-8,Edge], [9:0-1-8,Edge], [14:0-1-8,Edge], [19:0-1-8,Edge]

Loading	(psf)	Spacing	2-0-0	CSI	DEFL	in	(loc)	l/defl	L/d	PLATES	GRIP	
TCLL	40.0	Plate Grip DOL	1.00	TC	0.54	Vert(LL)	-0.12	15-16	>999	480	MT20	185/148
TCDL	10.0	Lumber DOL	1.00	BC	0.57	Vert(CT)	-0.19	13-14	>935	360		
BCLL	0.0	Rep Stress Incr	YES	WB	0.43	Horz(CT)	0.03	13	n/a	n/a		
BCDL	5.0	Code	IRC2021/TPI2014	Matrix-S								
											Weight: 106 lb	FT = 20%F, 11%E

LUMBER

TOP CHORD 2x4 HF-N No.1/No.2(flat)
 BOT CHORD 2x4 HF-N No.1/No.2(flat)
 WEBS 2x4 DF Stud(flat)
 OTHERS 2x4 DF Stud(flat)

5) CAUTION, Do not erect truss backwards.

LOAD CASE(S) Standard

BRACING

TOP CHORD Structural wood sheathing directly applied or 6-0-0 oc purlins, except end verticals.
 BOT CHORD Rigid ceiling directly applied or 6-0-0 oc bracing.

REACTIONS

(size) 13=0-5-8, 17=0-2-9, 21=0-3-8
 Max Grav 13=723 (LC 7), 17=1630 (LC 8), 21=435 (LC 3)

FORCES

(lb) - Maximum Compression/Maximum Tension

TOP CHORD 1-21=-126/0, 12-13=-103/0, 1-2=0/0, 2-3=-621/60, 3-4=-621/60, 4-5=0/1295, 5-6=0/1295, 6-7=-1503/0, 7-9=-1503/0, 9-10=-1742/0, 10-11=-1742/0, 11-12=-5/0
 BOT CHORD 20-21=-60/621, 19-20=-60/621, 17-19=-407/243, 16-17=-261/633, 15-16=0/1742, 14-15=0/1742, 13-14=0/1152
 WEBS 5-17=-270/0, 4-17=-1170/0, 2-21=-701/68, 4-19=0/653, 2-20=-43/36, 3-19=-247/0, 6-17=-1622/0, 11-13=-1295/0, 6-16=0/1098, 11-14=0/669, 7-16=-296/0, 10-14=-233/0, 9-16=-578/0, 9-15=-66/73

NOTES

- 1) Unbalanced floor live loads have been considered for this design.
- 2) Attach ribbon block to truss with 3-10d nails applied to flat face.
- 3) Provide mechanical connection (by others) of truss to bearing plate at joint(s) 17.
- 4) Recommend 2x6 strongbacks, on edge, spaced at 10-00-00 oc and fastened to each truss with 3-10d (0.131" X 3") nails. Strongbacks to be attached to walls at their outer ends or restrained by other means.



November 4, 2025

WARNING - Verify design parameters and READ NOTES ON THIS AND INCLUDED MITEK REFERENCE PAGE MII-7473 rev. 1/2/2023 BEFORE USE.

Design valid for use only with MiTek® connectors. This design is based only upon parameters shown, and is for an individual building component, not a truss system. Before use, the building designer must verify the applicability of design parameters and properly incorporate this design into the overall building design. Bracing indicated is to prevent buckling of individual truss web and/or chord members only. Additional temporary and permanent bracing is always required for stability and to prevent collapse with possible personal injury and property damage. For general guidance regarding the fabrication, storage, delivery, erection and bracing of trusses and truss systems, see **ANSI/TPI1 Quality Criteria and DSB-22** available from Truss Plate Institute (www.tpinst.org) and **BCSI Building Component Safety Information** available from the Structural Building Component Association (www.sbcsccomponents.com)

MiTek®

400 Sunrise Ave., Suite 270
 Roseville, CA 95661
 916.755.3571 / MiTek-US.com

Job J1183948F2	Truss F21	Truss Type Floor	Qty 1	Ply 1	NW Eastside Builders LLC Job Reference (optional)	R91075012
-------------------	--------------	---------------------	----------	----------	--	-----------

The Truss Company (Sumner, WA), Sumner, WA - 98390,

Run: 25.30 E Aug 20 2025 Print: 25.30 E Aug 20 2025 MiTek Industries, Inc. Tue Nov 04 11:34:30

Page: 1

ID:BL3qPxV17x8JJ9dS16USLoz87XL-wz0p3vEBGW4Kloo?VR1ihkxHX43CAftGGhaC_wyMlcd

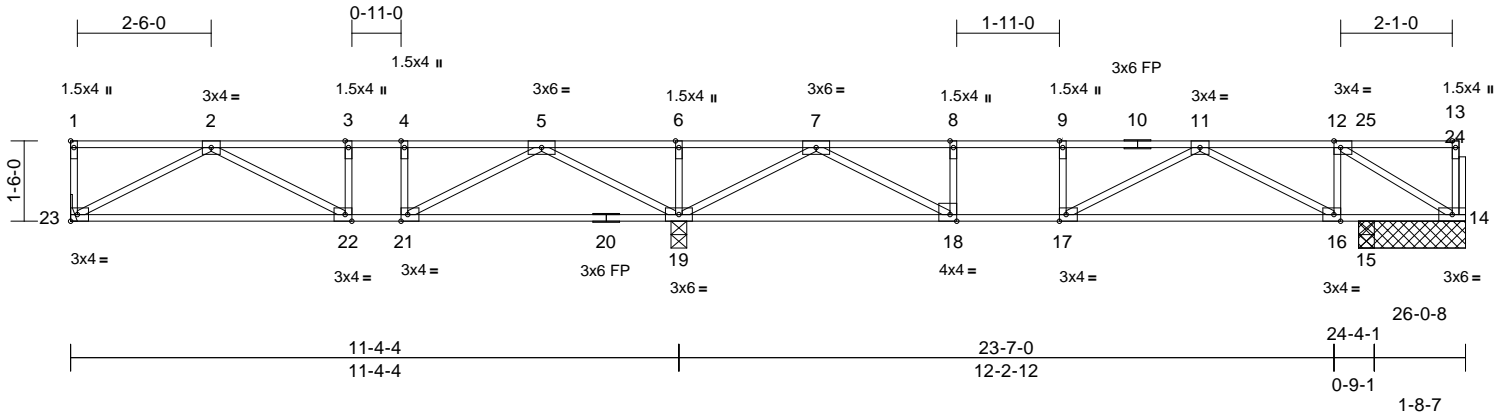

Scale = 1:43

Plate Offsets (X, Y): [1:Edge,0-0-12], [12:0-1-8,Edge], [16:0-1-8,Edge], [17:0-1-8,Edge], [18:0-1-8,Edge], [21:0-1-8,Edge], [22:0-1-8,Edge]

Loading	(psf)	Spacing	2-0-0	CSI	DEFL	in	(loc)	l/defl	L/d	PLATES	GRIP	
TCLL	40.0	Plate Grip DOL	1.00	TC	0.66	Vert(LL)	-0.26	16-17	>595	480	MT20	185/148
TCDL	10.0	Lumber DOL	1.00	BC	0.94	Vert(CT)	-0.38	16-17	>409	360		
BCLL	0.0	Rep Stress Incr	YES	WB	0.36	Horz(CT)	0.03	14	n/a	n/a		
BCDL	5.0	Code	IRC2021/TPI2014	Matrix-S							Weight: 113 lb	FT = 20%F, 11%E

LUMBER

TOP CHORD 2x4 HF-N No.1/No.2(flat)
 BOT CHORD 2x4 HF-N No.1/No.2(flat)
 WEBS 2x4 DF Stud(flat)
 OTHERS 2x4 DF Stud(flat)

- 4) Recommend 2x6 strongbacks, on edge, spaced at 10-00-00 oc and fastened to each truss with 3-10d (0.131" X 3") nails. Strongbacks to be attached to walls at their outer ends or restrained by other means.
 5) CAUTION, Do not erect truss backwards.

BRACING

TOP CHORD Structural wood sheathing directly applied or 6-0-0 oc purlins, except end verticals.
 BOT CHORD Rigid ceiling directly applied or 10-0-0 oc bracing, Except:
 6-0-0 oc bracing: 19-21
 2-2-0 oc bracing: 14-15.

LOAD CASE(S) Standard

REACTIONS

All bearings 0-3-8, except 23= Mechanical, 14=2-0-0
 (lb) - Max Grav All reactions 250 (lb) or less at joint (s) except 14=377 (LC 11), 15=466 (LC 14), 19=1493 (LC 1), 23=603 (LC 14)

FORCES

(lb) - Max. Comp./Max. Ten. - All forces 250 (lb) or less except when shown.
 TOP CHORD 2-3=-1225/0, 3-4=-1225/0, 4-5=-1225/0, 5-6=0/773, 6-7=0/773, 7-8=-1637/0, 8-9=-1637/0, 9-10=-1637/0, 10-11=-1637/0, 11-12=-621/0
 BOT CHORD 22-23=0/897, 21-22=0/1225, 20-21=-47/807, 19-20=-47/807, 18-19=0/875, 17-18=0/1637, 16-17=0/1415, 15-16=0/621, 14-15=0/621
 WEBS 6-19=-279/0, 5-19=-1192/0, 2-23=-1018/0, 5-21=0/686, 2-22=0/373, 4-21=-266/0, 11-16=-929/0, 7-19=-1365/0, 11-17=0/258, 7-18=0/934, 8-18=-358/0, 12-14=-721/0

NOTES

- Unbalanced floor live loads have been considered for this design.
- Attach ribbon block to truss with 3-10d nails applied to flat face.
- Refer to girder(s) for truss to truss connections.



November 4, 2025

WARNING - Verify design parameters and READ NOTES ON THIS AND INCLUDED MITEK REFERENCE PAGE MII-7473 rev. 1/2/2023 BEFORE USE.

Design valid for use only with MiTek® connectors. This design is based only upon parameters shown, and is for an individual building component, not a truss system. Before use, the building designer must verify the applicability of design parameters and properly incorporate this design into the overall building design. Bracing indicated is to prevent buckling of individual truss web and/or chord members only. Additional temporary and permanent bracing is always required for stability and to prevent collapse with possible personal injury and property damage. For general guidance regarding the fabrication, storage, delivery, erection and bracing of trusses and truss systems, see **ANSI/TPI1 Quality Criteria and DSB-22** available from Truss Plate Institute (www.tpinst.org) and **BCSI Building Component Safety Information** available from the Structural Building Component Association (www.sbcsccomponents.com)

MiTek®

400 Sunrise Ave., Suite 270
 Roseville, CA 95661
 916.755.3571 / MiTek-US.com

Job J1183948F2	Truss F20	Truss Type Floor	Qty 7	Ply 1	NW Eastside Builders LLC Job Reference (optional)	R91075013
-------------------	--------------	---------------------	----------	----------	--	-----------

The Truss Company (Sumner, WA), Sumner, WA - 98390,

Run: 25.30 S Oct 2 2025 Print: 25.3.0 S Oct 2 2025 MiTek Industries, Inc. Mon Nov 03 18:02:00
ID:BL3qPxV17x8JJ9dS16USLoz87XL-RfC?PsB70Hq3NSgPqnL8w3uITXbGKWrCDoi7J4zJC?f

Page: 1

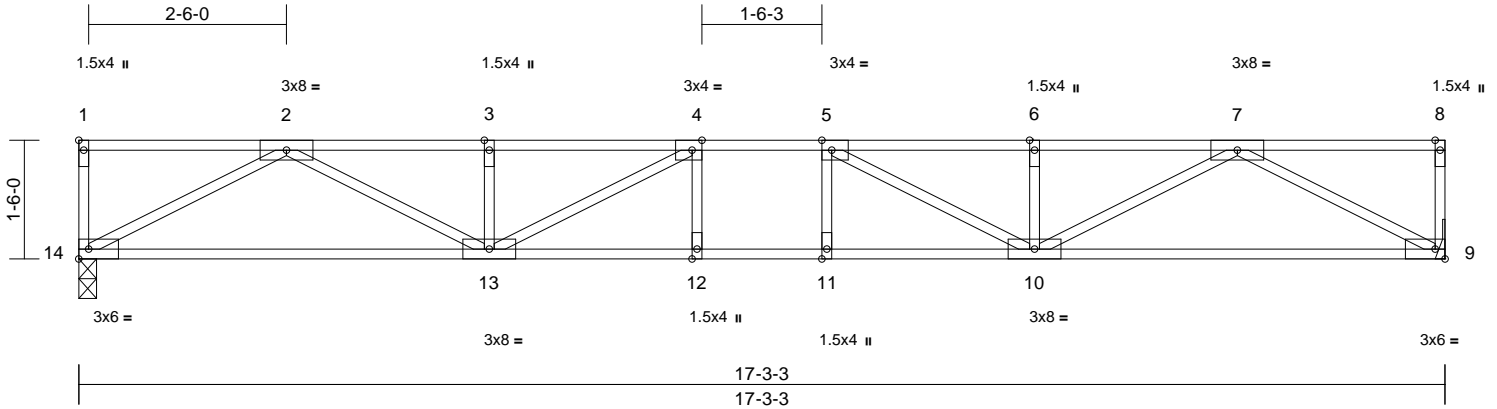

Scale = 1:29.1

Plate Offsets (X, Y): [1:Edge,0-0-12], [4:0-1-8,Edge], [5:0-1-8,Edge]

Loading	(psf)	Spacing	2-0-0	CSI	DEFL	in	(loc)	l/defl	L/d	PLATES	GRIP	
TCLL	40.0	Plate Grip DOL	1.00	TC	0.47	Vert(LL)	-0.18	12-13	>999	480	MT20	185/148
TCDL	10.0	Lumber DOL	1.00	BC	0.83	Vert(CT)	-0.24	12-13	>845	360		
BCLL	0.0	Rep Stress Incr	YES	WB	0.46	Horz(CT)	0.05	9	n/a	n/a		
BCDL	5.0	Code	IRC2021/TPI2014	Matrix-S							Weight: 76 lb	FT = 20%F, 11%E

LUMBER

TOP CHORD 2x4 HF-N No.1/No.2(flat)
BOT CHORD 2x4 HF-N No.1/No.2(flat)
WEBS 2x4 DF Stud(flat)

BRACING

TOP CHORD Structural wood sheathing directly applied or 6-0-0 oc purlins, except end verticals.
BOT CHORD Rigid ceiling directly applied or 10-0-0 oc bracing.

REACTIONS (size) 9= Mechanical, 14=0-2-11
Max Grav 9=943 (LC 1), 14=943 (LC 1)

FORCES (lb) - Maximum Compression/Maximum Tension

TOP CHORD 1-14=-105/0, 8-9=-105/0, 1-2=0/0,
2-3=-2514/0, 3-4=-2514/0, 4-5=-2931/0,
5-6=-2514/0, 6-7=-2514/0, 7-8=0/0
BOT CHORD 13-14=0/1524, 12-13=0/2931, 11-12=0/2931,
10-11=0/2931, 9-10=0/1524
WEBS 7-9=-1729/0, 2-14=-1729/0, 7-10=0/1124,
2-13=0/1124, 6-10=-298/0, 3-13=-298/0,
5-10=-691/0, 4-13=-691/0, 4-12=-96/119,
5-11=-96/119

NOTES

- 1) Unbalanced floor live loads have been considered for this design.
- 2) Refer to girder(s) for truss to truss connections.
- 3) Provide mechanical connection (by others) of truss to bearing plate at joint(s) 14.
- 4) Recommend 2x6 strongbacks, on edge, spaced at 10-00-00 oc and fastened to each truss with 3-10d (0.131" X 3") nails. Strongbacks to be attached to walls at their outer ends or restrained by other means.

LOAD CASE(S) Standard



November 4, 2025

WARNING - Verify design parameters and READ NOTES ON THIS AND INCLUDED MITEK REFERENCE PAGE MII-7473 rev. 1/2/2023 BEFORE USE.

Design valid for use only with MiTek® connectors. This design is based only upon parameters shown, and is for an individual building component, not a truss system. Before use, the building designer must verify the applicability of design parameters and properly incorporate this design into the overall building design. Bracing indicated is to prevent buckling of individual truss web and/or chord members only. Additional temporary and permanent bracing is always required for stability and to prevent collapse with possible personal injury and property damage. For general guidance regarding the fabrication, storage, delivery, erection and bracing of trusses and truss systems, see **ANSI/TPI1 Quality Criteria and DSB-22** available from Truss Plate Institute (www.tpinst.org) and **BCSI Building Component Safety Information** available from the Structural Building Component Association (www.sbcsccomponents.com)

MiTek®

400 Sunrise Ave., Suite 270
Roseville, CA 95661
916.755.3571 / MiTek-US.com

Job J1183948F2	Truss F19	Truss Type Floor	Qty 3	Ply 1	NW Eastside Builders LLC Job Reference (optional)	R91075014
-------------------	--------------	---------------------	----------	----------	--	-----------

The Truss Company (Sumner, WA), Sumner, WA - 98390,

Run: 25.30 S Oct 2 2025 Print: 25.3.0 S Oct 2 2025 MiTek Industries, Inc. Mon Nov 03 18:02:00
ID:j9VRCbU7Nd?Sh?2GTOzDoaz87XM-RfC?PsB70Hq3NSgPqnL8w3uITXbGKWRcDoi7J4zJC?f

Page: 1

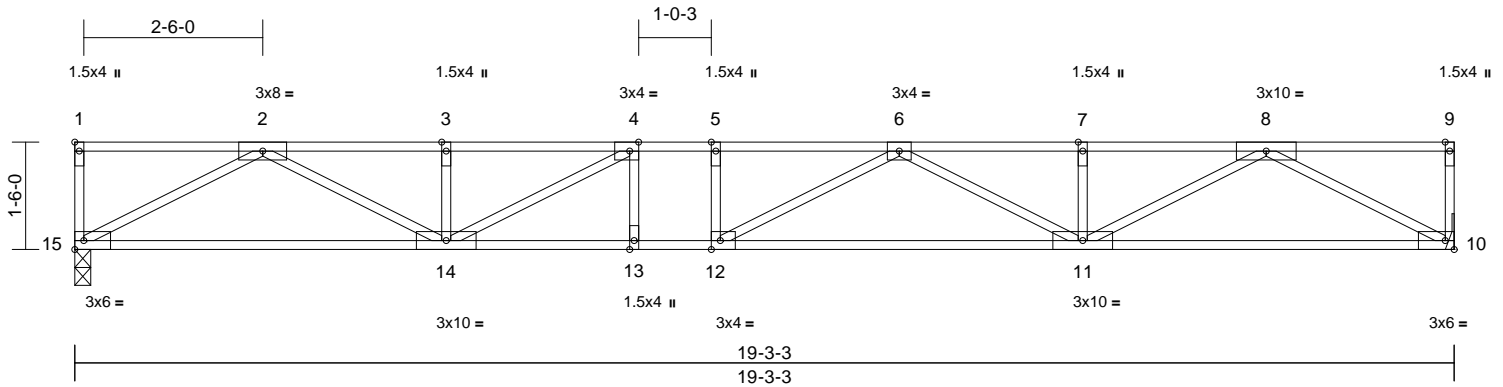

Scale = 1:32.2

Plate Offsets (X, Y): [1:Edge,0-0-12], [4:0-1-8,Edge], [12:0-1-8,Edge]

Loading	(psf)	Spacing	2-0-0	CSI	DEFL	in	(loc)	l/defl	L/d	PLATES	GRIP	
TCLL	40.0	Plate Grip DOL	1.00	TC	0.63	Vert(LL)	-0.30	11-12	>775	480	MT20	185/148
TCDL	10.0	Lumber DOL	1.00	BC	0.73	Vert(CT)	-0.43	11-12	>532	360		
BCLL	0.0	Rep Stress Incr	YES	WB	0.52	Horz(CT)	0.07	10	n/a	n/a		
BCDL	5.0	Code	IRC2021/TPI2014	Matrix-S							Weight: 87 lb	FT = 20%F, 11%E

LUMBER

TOP CHORD 2x4 HF-N No.1/No.2(flat)
 BOT CHORD 2x4 DF 1800F 1.6E or 2x4 DF No.1&Btr or 2x4 DF-N 1800F 1.6E(flat)
 WEBS 2x4 DF Stud(flat)

BRACING

TOP CHORD Structural wood sheathing directly applied or 5-9-9 oc purlins, except end verticals.
 BOT CHORD Rigid ceiling directly applied or 10-0-0 oc bracing.

REACTIONS (size) 10= Mechanical, 15=0-2-11
 Max Grav 10=1053 (LC 1), 15=1053 (LC 1)

FORCES (lb) - Maximum Compression/Maximum Tension

TOP CHORD 1-15=-104/0, 9-10=-102/0, 1-2=0/0, 2-3=-2908/0, 3-4=-2908/0, 4-5=-3613/0, 5-6=-3613/0, 6-7=-2922/0, 7-8=-2922/0, 8-9=0/0
 BOT CHORD 14-15=0/1728, 13-14=0/3613, 12-13=0/3613, 11-12=0/3549, 10-11=0/1734
 WEBS 8-10=-1968/0, 2-15=-1961/0, 8-11=0/1348, 2-14=0/1340, 7-11=-234/0, 3-14=-2777, 6-11=-711/0, 4-14=-946/0, 6-12=-256/444, 4-13=-68/167, 5-12=-115/16

NOTES

- 1) Unbalanced floor live loads have been considered for this design.
- 2) Refer to girder(s) for truss to truss connections.
- 3) Provide mechanical connection (by others) of truss to bearing plate at joint(s) 15.
- 4) Recommend 2x6 strongbacks, on edge, spaced at 10-00-00 oc and fastened to each truss with 3-10d (0.131" X 3") nails. Strongbacks to be attached to walls at their outer ends or restrained by other means.

LOAD CASE(S) Standard



November 4, 2025

WARNING - Verify design parameters and READ NOTES ON THIS AND INCLUDED MITEK REFERENCE PAGE MII-7473 rev. 1/2/2023 BEFORE USE.

Design valid for use only with MiTek® connectors. This design is based only upon parameters shown, and is for an individual building component, not a truss system. Before use, the building designer must verify the applicability of design parameters and properly incorporate this design into the overall building design. Bracing indicated is to prevent buckling of individual truss web and/or chord members only. Additional temporary and permanent bracing is always required for stability and to prevent collapse with possible personal injury and property damage. For general guidance regarding the fabrication, storage, delivery, erection and bracing of trusses and truss systems, see **ANSI/TPI1 Quality Criteria and DSB-22** available from Truss Plate Institute (www.tpinst.org) and **BCSI Building Component Safety Information** available from the Structural Building Component Association (www.sbcsccomponents.com)

MiTek®

400 Sunrise Ave., Suite 270
 Roseville, CA 95661
 916.755.3571 / MiTek-US.com

Job J1183948F2	Truss F18	Truss Type Floor	Qty 2	Ply 1	NW Eastside Builders LLC Job Reference (optional)	R91075015
-------------------	--------------	---------------------	----------	----------	--	-----------

The Truss Company (Sumner, WA), Sumner, WA - 98390,

Run: 25.30 S Oct 2 2025 Print: 25.3.0 S Oct 2 2025 MiTek Industries, Inc. Mon Nov 03 18:02:00
ID:2_9LN?1z6YyHOV0yqgdnQTz87MK-RfC?PsB70Hq3NSgPqnL8w3uTXbGKWrCDoi7J4zJC?f

Page: 1

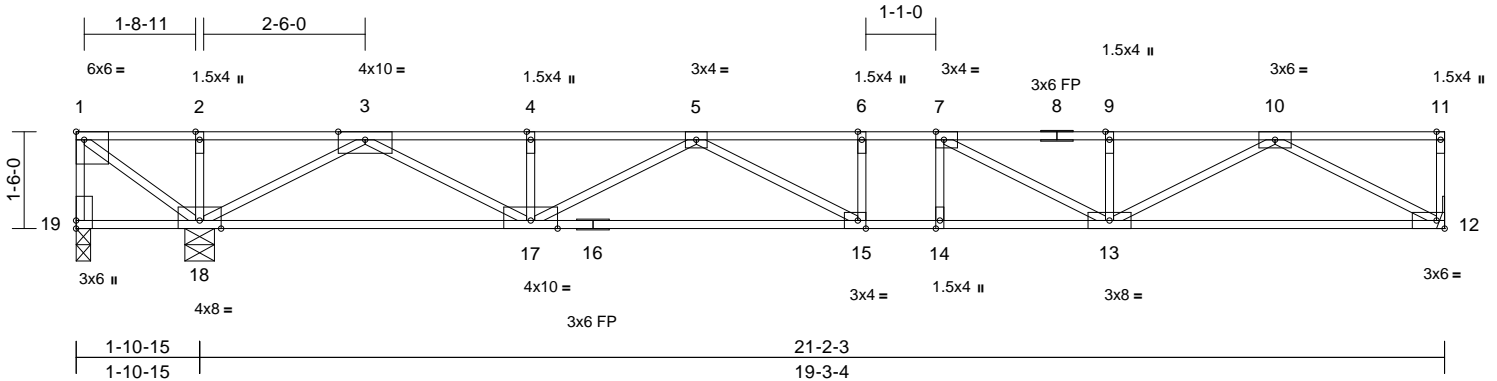

FASTEN TRUSS TO BEARING FOR THE UPLIFT REACTION SHOWN WHILE PERMITTING NO UPWARD MOVEMENT OF THE BEARING.

Scale = 1:35.7

Plate Offsets (X, Y): [1:Edge,0-1-8], [7:0-1-8,Edge], [15:0-1-8,Edge]

Loading	(psf)	Spacing	2-0-0	CSI	DEFL	in	(loc)	l/defl	L/d	PLATES	GRIP	
TCLL	40.0	Plate Grip DOL	1.00	TC	0.78	Vert(LL)	-0.18	15-17	>999	480	MT20	185/148
TCDL	10.0	Lumber DOL	1.00	BC	0.73	Vert(CT)	-0.27	15-17	>849	360		
BCLL	0.0	Rep Stress Incr	YES	WB	0.68	Horz(CT)	0.04	12	n/a	n/a		
BCDL	5.0	Code	IRC2021/TPI2014	Matrix-S							Weight: 94 lb	FT = 20%F, 11%E

LUMBER

TOP CHORD 2x4 HF-N No.1/No.2(flat)
BOT CHORD 2x4 HF-N No.1/No.2(flat)
WEBS 2x4 DF Stud(flat)

BRACING

TOP CHORD Structural wood sheathing directly applied or 6-0-0 oc purlins, except end verticals.
BOT CHORD Rigid ceiling directly applied or 10-0-0 oc bracing, Except:
6-0-0 oc bracing: 17-18.

REACTIONS

(size) 12= Mechanical, 18=0-5-8, 19=0-2-11
Max Uplift 19=-1732 (LC 4)
Max Grav 12=887 (LC 4), 18=3093 (LC 1), 19=-397 (LC 3)

FORCES

(lb) - Maximum Compression/Maximum Tension

TOP CHORD 1-19=0/1724, 11-12=-104/0, 1-2=0/2306, 2-3=0/2306, 3-4=-1201/0, 4-5=-1201/0, 5-6=-2607/0, 6-7=-2607/0, 7-9=-2309/0, 9-10=-2309/0, 10-11=0/0
BOT CHORD 18-19=0/0, 17-18=-319/0, 15-17=0/2151, 14-15=0/2607, 13-14=0/2607, 12-13=0/1420
WEBS 2-18=-263/0, 1-18=-2873/0, 3-18=-2266/0, 10-12=-1612/0, 3-17=0/1719, 10-13=0/1009, 4-17=-254/0, 9-13=-295/0, 5-17=-1079/0, 7-13=-551/43, 5-15=0/666, 6-15=-186/0, 7-14=-111/79

NOTES

- 1) Unbalanced floor live loads have been considered for this design.
- 2) Refer to girder(s) for truss to truss connections.
- 3) Provide mechanical connection (by others) of truss to bearing plate at joint(s) 19.
- 4) Provide mechanical connection (by others) of truss to bearing plate capable of withstanding 1732 lb uplift at joint 19.

- 5) This truss has large uplift reaction(s) from gravity load case(s). Proper connection is required to secure truss against upward movement at the bearings. Building designer must provide for uplift reactions indicated.
- 6) Recommend 2x6 strongbacks, on edge, spaced at 10-00-00 oc and fastened to each truss with 3-10d (0.131" X 3") nails. Strongbacks to be attached to walls at their outer ends or restrained by other means.
- 7) CAUTION, Do not erect truss backwards.

LOAD CASE(S) Standard



November 4, 2025

WARNING - Verify design parameters and READ NOTES ON THIS AND INCLUDED MITEK REFERENCE PAGE MII-7473 rev. 1/2/2023 BEFORE USE.

Design valid for use only with MiTek® connectors. This design is based only upon parameters shown, and is for an individual building component, not a truss system. Before use, the building designer must verify the applicability of design parameters and properly incorporate this design into the overall building design. Bracing indicated is to prevent buckling of individual truss web and/or chord members only. Additional temporary and permanent bracing is always required for stability and to prevent collapse with possible personal injury and property damage. For general guidance regarding the fabrication, storage, delivery, erection and bracing of trusses and truss systems, see **ANSI/TPI1 Quality Criteria and DSB-22** available from Truss Plate Institute (www.tpinst.org) and **BCSI Building Component Safety Information** available from the Structural Building Component Association (www.sbcsccomponents.com)

MiTek®

400 Sunrise Ave., Suite 270
Roseville, CA 95661
916.755.3571 / MiTek-US.com

Job J1183948F2	Truss F16	Truss Type Floor Supported Gable	Qty 1	Ply 1	NW Eastside Builders LLC Job Reference (optional)	R91075017
-------------------	--------------	-------------------------------------	----------	----------	--	-----------

The Truss Company (Sumner, WA), Sumner, WA - 98390,

Run: 25.30 S Oct 2 2025 Print: 25.3.0 S Oct 2 2025 MiTek Industries, Inc. Mon Nov 03 18:02:00
ID:j9VRCbU7Nd?Sh?2GTOzDoaz87XM-RfC?PsB70Hq3NSgPqnL8w3uITxbGKWrCDoi7J4zJC?f

Page: 1

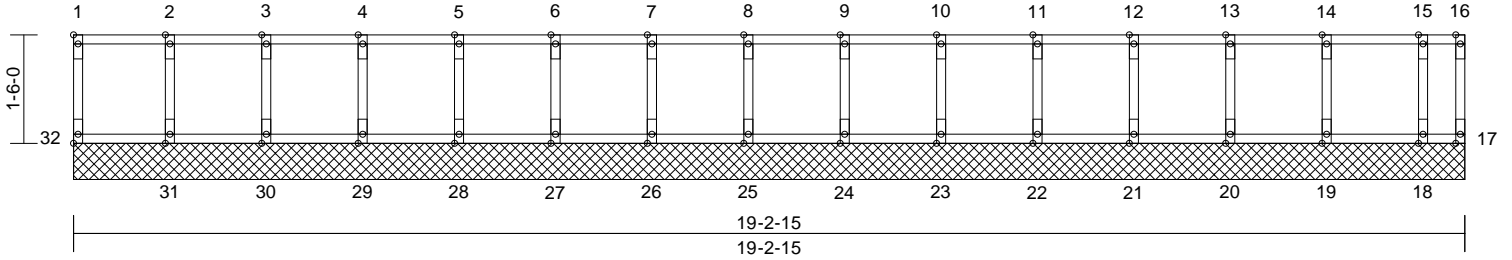

Scale = 1:31.9

Plate Offsets (X, Y): [1:Edge,0-0-12], [32:Edge,0-0-12]

Loading	(psf)	Spacing	2-0-0	CSI	DEFL	in	(loc)	l/defl	L/d	PLATES	GRIP	
TCLL	40.0	Plate Grip DOL	1.00	TC	0.06	Vert(LL)	n/a	-	n/a	999	MT20	185/148
TCDL	10.0	Lumber DOL	1.00	BC	0.01	Vert(TL)	n/a	-	n/a	999		
BCLL	0.0	Rep Stress Incr	YES	WB	0.03	Horiz(TL)	0.00	17	n/a	n/a		
BCDL	5.0	Code	IRC2021/TPI2014	Matrix-R							Weight: 75 lb	FT = 20%F, 11%E

LUMBER	WEBS
TOP CHORD 2x4 HF-N No.1/No.2(flat)	2-31=-141/0, 3-30=-132/0, 4-29=-134/0,
BOT CHORD 2x4 HF-N No.1/No.2(flat)	5-28=-133/0, 6-27=-133/0, 7-26=-133/0,
WEBS 2x4 DF Stud(flat)	8-25=-133/0, 9-24=-133/0, 10-23=-133/0,
OTHERS 2x4 DF Stud(flat)	11-22=-133/0, 12-21=-134/0, 13-20=-132/0,
	14-19=-139/0, 15-18=-103/0

BRACING	NOTES
TOP CHORD Structural wood sheathing directly applied or 6-0-0 oc purlins, except end verticals.	1) All plates are 1.5x4 () MT20 unless otherwise indicated.
BOT CHORD Rigid ceiling directly applied or 10-0-0 oc bracing.	2) Gable requires continuous bottom chord bearing.
	3) Truss to be fully sheathed from one face or securely braced against lateral movement (i.e. diagonal web).
	4) Gable studs spaced at 1'-4" oc.
	5) Recommend 2x6 strongbacks, on edge, spaced at 10-00-00 oc and fastened to each truss with 3-10d (0.131" X 3") nails. Strongbacks to be attached to walls at their outer ends or restrained by other means.

REACTIONS (size)	LOAD CASE(S) Standard
17=19-2-15, 18=19-2-15, 19=19-2-15, 20=19-2-15, 21=19-2-15, 22=19-2-15, 23=19-2-15, 24=19-2-15, 25=19-2-15, 26=19-2-15, 27=19-2-15, 28=19-2-15, 29=19-2-15, 30=19-2-15, 31=19-2-15, 32=19-2-15	
Max Grav 17=17 (LC 1), 18=109 (LC 1), 19=153 (LC 1), 20=145 (LC 1), 21=147 (LC 1), 22=147 (LC 1), 23=147 (LC 1), 24=147 (LC 1), 25=147 (LC 1), 26=147 (LC 1), 27=147 (LC 1), 28=147 (LC 1), 29=147 (LC 1), 30=145 (LC 1), 31=155 (LC 1), 32=60 (LC 1)	

FORCES (lb) - Maximum Compression/Maximum Tension
TOP CHORD 1-32=-54/0, 16-17=-11/0, 1-2=-4/0, 2-3=-4/0, 3-4=-4/0, 4-5=-4/0, 5-6=-4/0, 6-7=-4/0, 7-8=-4/0, 8-9=-4/0, 9-10=-4/0, 10-11=-4/0, 11-12=-4/0, 12-13=-4/0, 13-14=-4/0, 14-15=-4/0, 15-16=-4/0
BOT CHORD 31-32=0/4, 30-31=0/4, 29-30=0/4, 28-29=0/4, 27-28=0/4, 26-27=0/4, 25-26=0/4, 24-25=0/4, 23-24=0/4, 22-23=0/4, 21-22=0/4, 20-21=0/4, 19-20=0/4, 18-19=0/4, 17-18=0/4



November 4, 2025

WARNING - Verify design parameters and READ NOTES ON THIS AND INCLUDED MITEK REFERENCE PAGE MII-7473 rev. 1/2/2023 BEFORE USE.

Design valid for use only with MiTek® connectors. This design is based only upon parameters shown, and is for an individual building component, not a truss system. Before use, the building designer must verify the applicability of design parameters and properly incorporate this design into the overall building design. Bracing indicated is to prevent buckling of individual truss web and/or chord members only. Additional temporary and permanent bracing is always required for stability and to prevent collapse with possible personal injury and property damage. For general guidance regarding the fabrication, storage, delivery, erection and bracing of trusses and truss systems, see **ANSI/TPI1 Quality Criteria and DSB-22** available from Truss Plate Institute (www.tpinst.org) and **BCSI Building Component Safety Information** available from the Structural Building Component Association (www.sbcsccomponents.com)

MiTek®

400 Sunrise Ave., Suite 270
Roseville, CA 95661
916.755.3571 / MiTek-US.com

Job J1183948F2	Truss F15	Truss Type Floor Supported Gable	Qty 1	Ply 1	NW Eastside Builders LLC Job Reference (optional) R91075018
-------------------	--------------	-------------------------------------	----------	----------	---

The Truss Company (Sumner, WA), Sumner, WA - 98390,

Run: 25.30 S Oct 2 2025 Print: 25.3.0 S Oct 2 2025 MiTek Industries, Inc. Mon Nov 03 18:02:00
ID:j9VRCbU7Nd?Sh?2GTOzDoaz87XM-RfC?PsB70Hq3NSgPqnL8w3uITXbGKWrCDoi7J4zJC?f

Page: 1

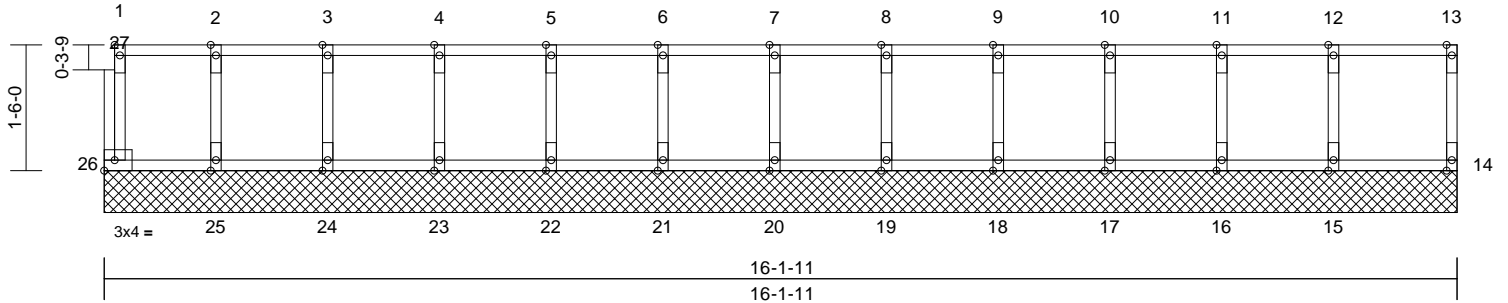

Scale = 1:27.5

Plate Offsets (X, Y): [1:Edge,0-0-12]

Loading	(psf)	Spacing	2-0-0	CSI	DEFL	in	(loc)	l/defl	L/d	PLATES	GRIP	
TCLL	40.0	Plate Grip DOL	1.00	TC	0.07	Vert(LL)	n/a	-	n/a	999	MT20	185/148
TCDL	10.0	Lumber DOL	1.00	BC	0.01	Vert(TL)	n/a	-	n/a	999		
BCLL	0.0	Rep Stress Incr	YES	WB	0.03	Horiz(TL)	0.00	14	n/a	n/a		
BCDL	5.0	Code	IRC2021/TPI2014	Matrix-R							Weight: 64 lb	FT = 20%F, 11%E

LUMBER

TOP CHORD 2x4 HF-N No.1/No.2(flat)
BOT CHORD 2x4 HF-N No.1/No.2(flat)
WEBS 2x4 DF Stud(flat)
OTHERS 2x4 DF Stud(flat)

BRACING

TOP CHORD Structural wood sheathing directly applied or 6-0-0 oc purlins, except end verticals.
BOT CHORD Rigid ceiling directly applied or 10-0-0 oc bracing.

REACTIONS (size) 14=16-1-11, 15=16-1-11,
16=16-1-11, 17=16-1-11,
18=16-1-11, 19=16-1-11,
20=16-1-11, 21=16-1-11,
22=16-1-11, 23=16-1-11,
24=16-1-11, 25=16-1-11,
26=16-1-11

Max Grav 14=72 (LC 1), 15=159 (LC 1),
16=143 (LC 1), 17=148 (LC 1),
18=146 (LC 1), 19=147 (LC 1),
20=147 (LC 1), 21=147 (LC 1),
22=147 (LC 1), 23=146 (LC 1),
24=148 (LC 1), 25=142 (LC 1),
26=57 (LC 1)

FORCES (lb) - Maximum Compression/Maximum Tension

TOP CHORD 1-26=-51/0, 13-14=-64/0, 1-2=-8/0, 2-3=-8/0,
3-4=-8/0, 4-5=-8/0, 5-6=-8/0, 6-7=-8/0,
7-8=-8/0, 8-9=-8/0, 9-10=-8/0, 10-11=-8/0,
11-12=-8/0, 12-13=-8/0

BOT CHORD 25-26=0/8, 24-25=0/8, 23-24=0/8, 22-23=0/8,
21-22=0/8, 20-21=0/8, 19-20=0/8, 18-19=0/8,
17-18=0/8, 16-17=0/8, 15-16=0/8, 14-15=0/8

WEBS 2-25=-130/0, 3-24=-134/0, 4-23=-133/0,
5-22=-133/0, 6-21=-133/0, 7-20=-133/0,
8-19=-133/0, 9-18=-133/0, 10-17=-134/0,
11-16=-130/0, 12-15=-147/0

NOTES

- All plates are 1.5x4 (||) MT20 unless otherwise indicated.
- Attach ribbon block to truss with 3-10d nails applied to flat face.
- Gable requires continuous bottom chord bearing.
- Truss to be fully sheathed from one face or securely braced against lateral movement (i.e. diagonal web).
- Gable studs spaced at 1-4-0 oc.
- Recommend 2x6 strongbacks, on edge, spaced at 10-00-00 oc and fastened to each truss with 3-10d (0.131" X 3") nails. Strongbacks to be attached to walls at their outer ends or restrained by other means.
- CAUTION, Do not erect truss backwards.

LOAD CASE(S) Standard



November 4, 2025

WARNING - Verify design parameters and READ NOTES ON THIS AND INCLUDED MITEK REFERENCE PAGE MII-7473 rev. 1/2/2023 BEFORE USE.

Design valid for use only with MiTek® connectors. This design is based only upon parameters shown, and is for an individual building component, not a truss system. Before use, the building designer must verify the applicability of design parameters and properly incorporate this design into the overall building design. Bracing indicated is to prevent buckling of individual truss web and/or chord members only. Additional temporary and permanent bracing is always required for stability and to prevent collapse with possible personal injury and property damage. For general guidance regarding the fabrication, storage, delivery, erection and bracing of trusses and truss systems, see **ANSI/TPI1 Quality Criteria and DSB-22** available from Truss Plate Institute (www.tpinst.org) and **BCSI Building Component Safety Information** available from the Structural Building Component Association (www.sbcsccomponents.com)

MiTek®

400 Sunrise Ave., Suite 270
Roseville, CA 95661
916.755.3571 / MiTek-US.com

Job J1183948F2	Truss F14	Truss Type Floor	Qty 1	Ply 1	NW Eastside Builders LLC Job Reference (optional)	R91075019
-------------------	--------------	---------------------	----------	----------	--	-----------

The Truss Company (Sumner, WA), Sumner, WA - 98390,

Run: 25.30 S Oct 2 2025 Print: 25.3.0 S Oct 2 2025 MiTek Industries, Inc. Mon Nov 03 18:01:59
ID:j9VRCbU7Nd?Sh?2GTOzDoaz87XM-RfC?PsB70Hq3NSgPqnL8w3uITXbGKWrCdoi7J4zJC?f

Page: 1

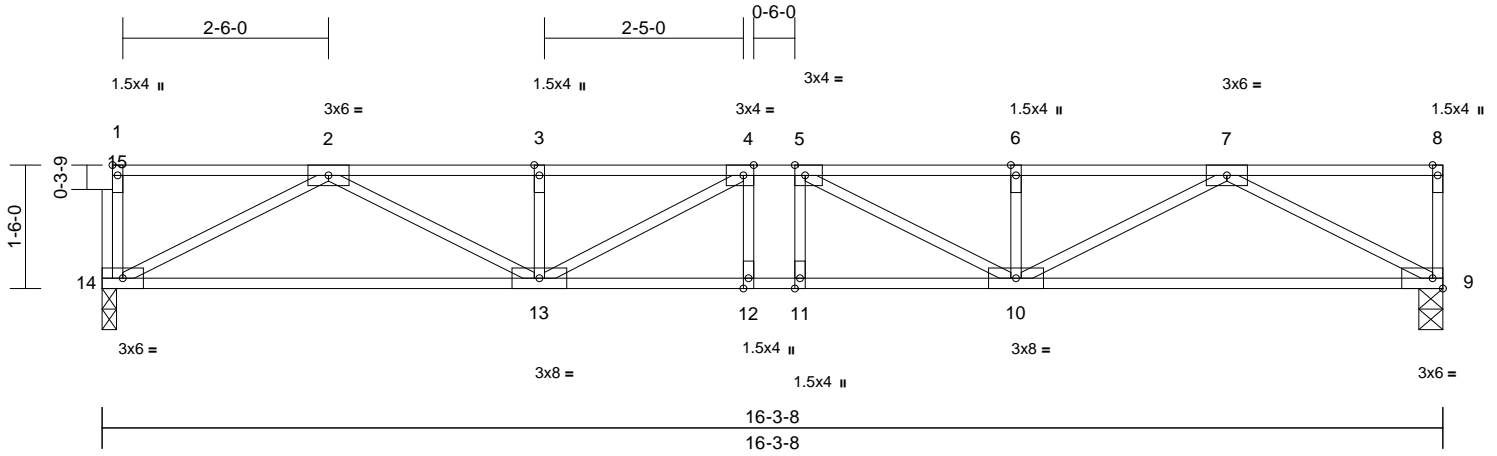

Scale = 1:28

Plate Offsets (X, Y): [1:Edge,0-0-12], [4:0-1-8,Edge], [5:0-1-8,Edge]

Loading	(psf)	Spacing	2-0-0	CSI	DEFL	in	(loc)	l/defl	L/d	PLATES	GRIP	
TCLL	40.0	Plate Grip DOL	1.00	TC	0.31	Vert(LL)	-0.14	11	>999	480	MT20	185/148
TCDL	10.0	Lumber DOL	1.00	BC	0.68	Vert(CT)	-0.19	11-12	>999	360		
BCLL	0.0	Rep Stress Incr	YES	WB	0.43	Horz(CT)	0.05	9	n/a	n/a		
BCDL	5.0	Code	IRC2021/TPI2014	Matrix-S							Weight: 75 lb	FT = 20%F, 11%E

LUMBER

TOP CHORD 2x4 HF-N No.1/No.2(flat)
 BOT CHORD 2x4 HF-N No.1/No.2(flat)
 WEBS 2x4 DF Stud(flat)
 OTHERS 2x4 DF Stud(flat)

BRACING

TOP CHORD Structural wood sheathing directly applied or 6-0-0 oc purlins, except end verticals.
 BOT CHORD Rigid ceiling directly applied or 10-0-0 oc bracing.

REACTIONS (size) 9=0-3-8, 14=0-2-1
 Max Grav 9=886 (LC 1), 14=879 (LC 1)

FORCES (lb) - Maximum Compression/Maximum Tension

TOP CHORD 1-14=-104/0, 8-9=-104/0, 1-2=-5/0,
 2-3=-2314/0, 3-4=-2314/0, 4-5=-2610/0,
 5-6=-2302/0, 6-7=-2302/0, 7-8=0/0
 BOT CHORD 13-14=0/1445, 12-13=0/2610, 11-12=0/2610,
 10-11=0/2610, 9-10=0/1418
 WEBS 7-9=-1609/0, 2-14=-1626/0, 7-10=0/1003,
 2-13=0/987, 6-10=-277/0, 3-13=-273/0,
 5-10=-513/32, 4-13=-505/41, 4-12=-111/124,
 5-11=-113/120

NOTES

- 1) Unbalanced floor live loads have been considered for this design.
- 2) Attach ribbon block to truss with 3-10d nails applied to flat face.
- 3) Provide mechanical connection (by others) of truss to bearing plate at joint(s) 14.
- 4) Recommend 2x6 strongbacks, on edge, spaced at 10-00-00 oc and fastened to each truss with 3-10d (0.131" X 3") nails. Strongbacks to be attached to walls at their outer ends or restrained by other means.
- 5) CAUTION, Do not erect truss backwards.

LOAD CASE(S) Standard



November 4, 2025

WARNING - Verify design parameters and READ NOTES ON THIS AND INCLUDED MITEK REFERENCE PAGE MII-7473 rev. 1/2/2023 BEFORE USE.

Design valid for use only with MiTek® connectors. This design is based only upon parameters shown, and is for an individual building component, not a truss system. Before use, the building designer must verify the applicability of design parameters and properly incorporate this design into the overall building design. Bracing indicated is to prevent buckling of individual truss web and/or chord members only. Additional temporary and permanent bracing is always required for stability and to prevent collapse with possible personal injury and property damage. For general guidance regarding the fabrication, storage, delivery, erection and bracing of trusses and truss systems, see **ANSI/TPI1 Quality Criteria and DSB-22** available from Truss Plate Institute (www.tpinst.org) and **BCSI Building Component Safety Information** available from the Structural Building Component Association (www.sbcsccomponents.com)

MiTek®

400 Sunrise Ave., Suite 270
 Roseville, CA 95661
 916.755.3571 / MiTek-US.com

Job J1183948F2	Truss F13	Truss Type Floor	Qty 6	Ply 1	NW Eastside Builders LLC Job Reference (optional)	R91075020
-------------------	--------------	---------------------	----------	----------	--	-----------

The Truss Company (Sumner, WA), Sumner, WA - 98390,

Run: 25.30 S Oct 2 2025 Print: 25.3.0 S Oct 2 2025 MiTek Industries, Inc. Mon Nov 03 18:01:59
ID:j9VRCbU7Nd?Sh?2GTOzDoaz87XM-RfC?PsB70Hq3NSgPqnL8w3uITXbGKWrCdoi7J4zJC?f

Page: 1

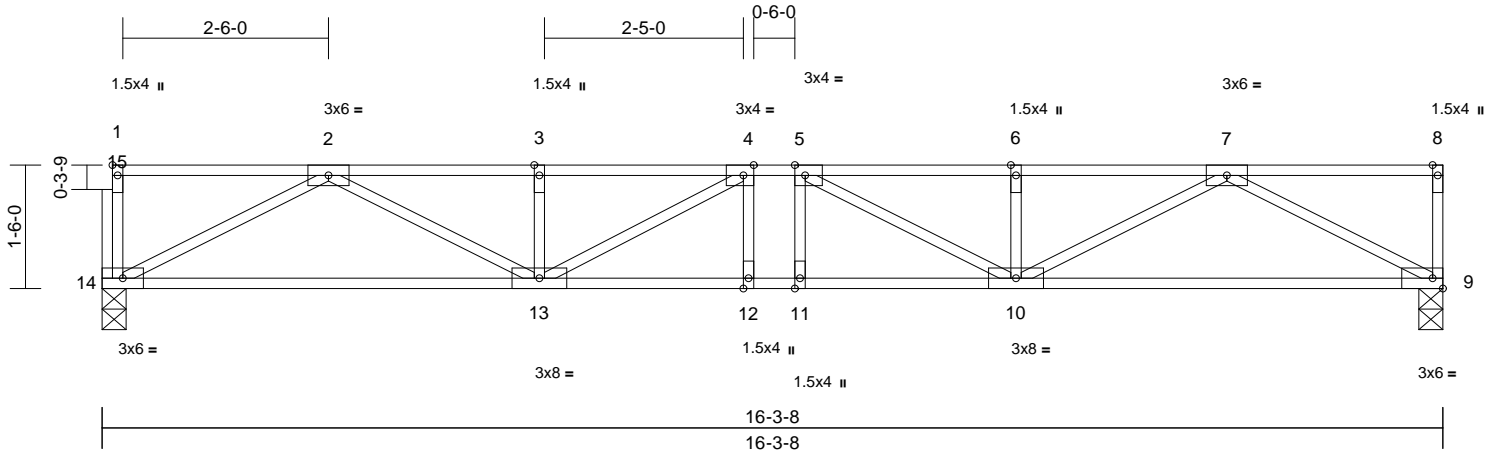

Scale = 1:28

Plate Offsets (X, Y): [1:Edge,0-0-12], [4:0-1-8,Edge], [5:0-1-8,Edge]

Loading	(psf)	Spacing	2-0-0	CSI	DEFL	in	(loc)	l/defl	L/d	PLATES	GRIP	
TCLL	40.0	Plate Grip DOL	1.00	TC	0.31	Vert(LL)	-0.14	11	>999	480	MT20	185/148
TCDL	10.0	Lumber DOL	1.00	BC	0.68	Vert(CT)	-0.19	11-12	>999	360		
BCLL	0.0	Rep Stress Incr	YES	WB	0.43	Horz(CT)	0.05	9	n/a	n/a		
BCDL	5.0	Code	IRC2021/TPI2014	Matrix-S							Weight: 75 lb	FT = 20%F, 11%E

LUMBER

TOP CHORD 2x4 HF-N No.1/No.2(flat)
 BOT CHORD 2x4 HF-N No.1/No.2(flat)
 WEBS 2x4 DF Stud(flat)
 OTHERS 2x4 DF Stud(flat)

BRACING

TOP CHORD Structural wood sheathing directly applied or 6-0-0 oc purlins, except end verticals.
 BOT CHORD Rigid ceiling directly applied or 10-0-0 oc bracing.

REACTIONS (size) 9=0-3-8, 14=0-3-8

Max Grav 9=886 (LC 1), 14=879 (LC 1)

FORCES (lb) - Maximum Compression/Maximum Tension

TOP CHORD 1-14=-104/0, 8-9=-104/0, 1-2=-5/0,
 2-3=-2314/0, 3-4=-2314/0, 4-5=-2610/0,
 5-6=-2302/0, 6-7=-2302/0, 7-8=0/0
 BOT CHORD 13-14=0/1445, 12-13=0/2610, 11-12=0/2610,
 10-11=0/2610, 9-10=0/1418
 WEBS 7-9=-1609/0, 2-14=-1626/0, 7-10=0/1003,
 2-13=0/987, 6-10=-277/0, 3-13=-273/0,
 5-10=-513/32, 4-13=-505/41, 4-12=-111/124,
 5-11=-113/120

NOTES

- 1) Unbalanced floor live loads have been considered for this design.
- 2) Attach ribbon block to truss with 3-10d nails applied to flat face.
- 3) Recommend 2x6 strongbacks, on edge, spaced at 10-00-00 oc and fastened to each truss with 3-10d (0.131" X 3") nails. Strongbacks to be attached to walls at their outer ends or restrained by other means.
- 4) CAUTION, Do not erect truss backwards.

LOAD CASE(S) Standard



November 4, 2025

WARNING - Verify design parameters and READ NOTES ON THIS AND INCLUDED MITEK REFERENCE PAGE MII-7473 rev. 1/2/2023 BEFORE USE.

Design valid for use only with MiTek® connectors. This design is based only upon parameters shown, and is for an individual building component, not a truss system. Before use, the building designer must verify the applicability of design parameters and properly incorporate this design into the overall building design. Bracing indicated is to prevent buckling of individual truss web and/or chord members only. Additional temporary and permanent bracing is always required for stability and to prevent collapse with possible personal injury and property damage. For general guidance regarding the fabrication, storage, delivery, erection and bracing of trusses and truss systems, see **ANSI/TPI1 Quality Criteria and DSB-22** available from Truss Plate Institute (www.tpinst.org) and **BCSI Building Component Safety Information** available from the Structural Building Component Association (www.sbcsccomponents.com)

MiTek®

400 Sunrise Ave., Suite 270
 Roseville, CA 95661
 916.755.3571 / MiTek-US.com

Job J1183948F2	Truss F12	Truss Type Floor Supported Gable	Qty 1	Ply 1	NW Eastside Builders LLC Job Reference (optional)	R91075021
-------------------	--------------	-------------------------------------	----------	----------	--	-----------

The Truss Company (Sumner, WA), Sumner, WA - 98390,

Run: 25.30 S Oct 2 2025 Print: 25.3.0 S Oct 2 2025 MiTek Industries, Inc. Mon Nov 03 18:01:59
ID:Fzx3_FUVcKtb4rT4vhS_GNz87XN-RfC?PsB70Hq3NSgPqnL8w3uITxbGKWrCDoi7J4zJC?f

Page: 1

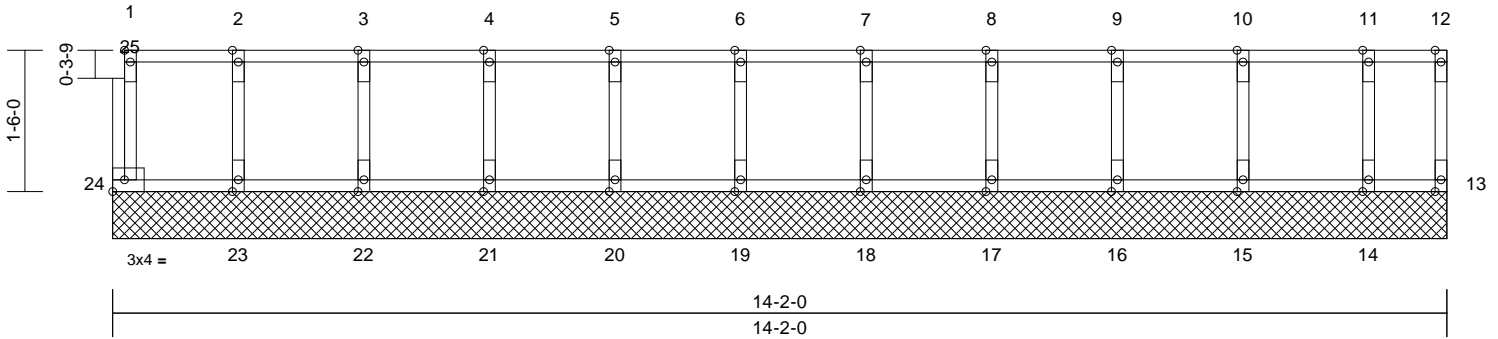

Scale = 1:24.5

Plate Offsets (X, Y): [1:Edge,0-0-12]

Loading	(psf)	Spacing	2-0-0	CSI	DEFL	in	(loc)	l/defl	L/d	PLATES	GRIP	
TCLL	40.0	Plate Grip DOL	1.00	TC	0.06	Vert(LL)	n/a	-	n/a	999	MT20	185/148
TCDL	10.0	Lumber DOL	1.00	BC	0.01	Vert(TL)	n/a	-	n/a	999		
BCLL	0.0	Rep Stress Incr	YES	WB	0.03	Horiz(TL)	0.00	13	n/a	n/a		
BCDL	5.0	Code	IRC2021/TPI2014	Matrix-R							Weight: 57 lb	FT = 20%F, 11%E

LUMBER

TOP CHORD 2x4 HF-N No.1/No.2(flat)
 BOT CHORD 2x4 HF-N No.1/No.2(flat)
 WEBS 2x4 DF Stud(flat)
 OTHERS 2x4 DF Stud(flat)

BRACING

TOP CHORD Structural wood sheathing directly applied or 6-0-0 oc purlins, except end verticals.
 BOT CHORD Rigid ceiling directly applied or 10-0-0 oc bracing.

REACTIONS (size) 13=14-2-0, 14=14-2-0, 15=14-2-0, 16=14-2-0, 17=14-2-0, 18=14-2-0, 19=14-2-0, 20=14-2-0, 21=14-2-0, 22=14-2-0, 23=14-2-0, 24=14-2-0
 Max Grav 13=35 (LC 1), 14=119 (LC 1), 15=152 (LC 1), 16=145 (LC 1), 17=147 (LC 1), 18=147 (LC 1), 19=147 (LC 1), 20=147 (LC 1), 21=147 (LC 1), 22=146 (LC 1), 23=149 (LC 1), 24=51 (LC 1)

FORCES (lb) - Maximum Compression/Maximum Tension

TOP CHORD 1-24=-48/0, 12-13=-28/0, 1-2=-4/0, 2-3=-4/0, 3-4=-4/0, 4-5=-4/0, 5-6=-4/0, 6-7=-4/0, 7-8=-4/0, 8-9=-4/0, 9-10=-4/0, 10-11=-4/0, 11-12=-4/0
 BOT CHORD 23-24=0/4, 22-23=0/4, 21-22=0/4, 20-21=0/4, 19-20=0/4, 18-19=0/4, 17-18=0/4, 16-17=0/4, 15-16=0/4, 14-15=0/4, 13-14=0/4
 WEBS 2-23=-133/0, 3-22=-134/0, 4-21=-133/0, 5-20=-133/0, 6-19=-133/0, 7-18=-133/0, 8-17=-134/0, 9-16=-132/0, 10-15=-138/0, 11-14=-112/0

NOTES

- All plates are 1.5x4 (||) MT20 unless otherwise indicated.
- Attach ribbon block to truss with 3-10d nails applied to flat face.

- Gable requires continuous bottom chord bearing.
- Truss to be fully sheathed from one face or securely braced against lateral movement (i.e. diagonal web).
- Gable studs spaced at 1'-4" oc.
- Recommend 2x6 strongbacks, on edge, spaced at 10'-0" oc and fastened to each truss with 3-10d (0.131" X 3") nails. Strongbacks to be attached to walls at their outer ends or restrained by other means.
- CAUTION, Do not erect truss backwards.

LOAD CASE(S) Standard



November 4, 2025

WARNING - Verify design parameters and READ NOTES ON THIS AND INCLUDED MITEK REFERENCE PAGE MII-7473 rev. 1/2/2023 BEFORE USE.

Design valid for use only with MiTek® connectors. This design is based only upon parameters shown, and is for an individual building component, not a truss system. Before use, the building designer must verify the applicability of design parameters and properly incorporate this design into the overall building design. Bracing indicated is to prevent buckling of individual truss web and/or chord members only. Additional temporary and permanent bracing is always required for stability and to prevent collapse with possible personal injury and property damage. For general guidance regarding the fabrication, storage, delivery, erection and bracing of trusses and truss systems, see **ANSI/TPI1 Quality Criteria and DSB-22** available from Truss Plate Institute (www.tpinst.org) and **BCSI Building Component Safety Information** available from the Structural Building Component Association (www.sbcsccomponents.com)

MiTek®

400 Sunrise Ave., Suite 270
 Roseville, CA 95661
 916.755.3571 / MiTek-US.com

Job J1183948F2	Truss F11	Truss Type Floor	Qty 1	Ply 1	NW Eastside Builders LLC Job Reference (optional)	R91075022
-------------------	--------------	---------------------	----------	----------	--	-----------

The Truss Company (Sumner, WA), Sumner, WA - 98390,

Run: 25.30 S Oct 2 2025 Print: 25.3.0 S Oct 2 2025 MiTek Industries, Inc. Mon Nov 03 18:01:59
ID:BL3qPxV17x8JJ9dS16USLoz87XL-RfC?PsB70Hq3NSgPqnlL8w3uTXbGKwRCD0i7J4zJC?f

Page: 1

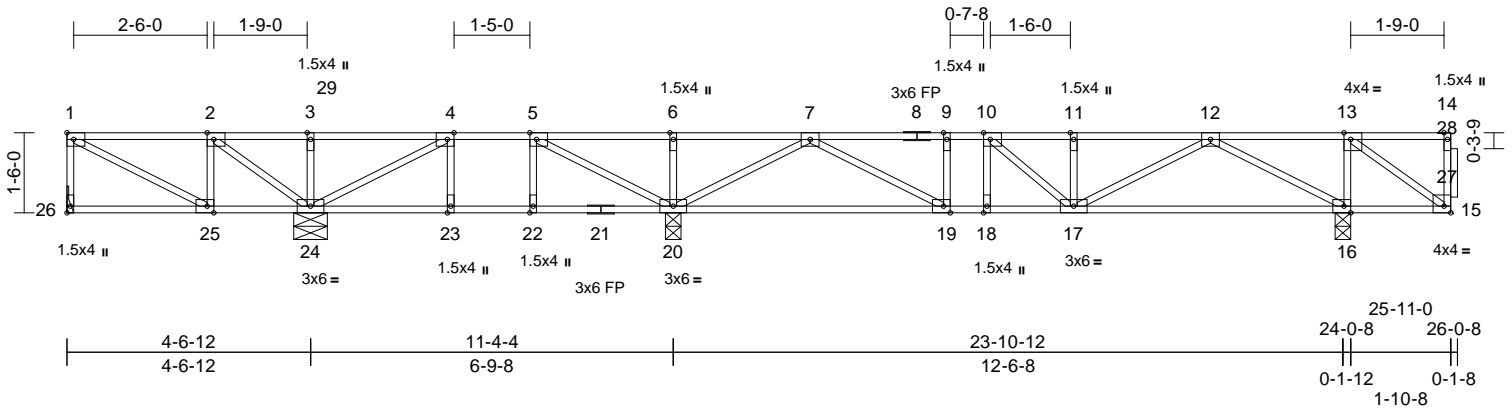

Scale = 1:43.2

Plate Offsets (X, Y): [2:0-1-8,Edge], [4:0-1-8,Edge], [5:0-1-8,Edge], [10:0-1-8,Edge], [13:0-1-8,Edge], [15:Edge,0-1-8], [16:0-1-8,Edge], [19:0-1-8,Edge], [25:0-1-8,Edge], [26:Edge,0-0-12]

Loading	(psf)	Spacing	2-0-0	CSI	DEFL	in	(loc)	l/defl	L/d	PLATES	GRIP	
TCLL	40.0	Plate Grip DOL	1.00	TC	0.43	Vert(LL)	-0.06	17-18	>999	480	MT20	185/148
TCDL	10.0	Lumber DOL	1.00	BC	0.35	Vert(CT)	-0.07	19-20	>999	360		
BCLL	0.0	Rep Stress Incr	NO	WB	0.37	Horz(CT)	0.01	16	n/a	n/a		
BCDL	5.0	Code	IRC2021/TPI2014	Matrix-S								
											Weight: 119 lb	FT = 20%F, 11%E

LUMBER

TOP CHORD 2x4 HF-N No.1/No.2(flat)
 BOT CHORD 2x4 HF-N No.1/No.2(flat)
 WEBS 2x4 DF Stud(flat)
 OTHERS 2x4 DF Stud(flat)

BRACING

TOP CHORD Structural wood sheathing directly applied or 6-0-0 oc purlins, except end verticals.
 BOT CHORD Rigid ceiling directly applied or 6-0-0 oc bracing, Except: 10-0-0 oc bracing: 25-26.

REACTIONS (size) 16=0-3-8, 20=0-3-8, 24=0-7-8, 26= Mechanical
 Max Uplift 26=78 (LC 6)
 Max Grav 16=1286 (LC 7), 20=1122 (LC 21), 24=793 (LC 20), 26=165 (LC 5)

FORCES (lb) - Maximum Compression/Maximum Tension

TOP CHORD 1-26=-154/89, 14-15=-529/0, 1-2=-85/216, 2-3=0/570, 3-4=0/570, 4-5=-233/344, 5-6=0/648, 6-7=0/648, 7-9=-1060/4, 9-10=-1060/4, 10-11=-1051/96, 11-12=-1051/96, 12-13=0/717, 13-14=0/0
 BOT CHORD 25-26=0/0, 24-25=-216/85, 23-24=-344/233, 22-23=-344/233, 20-22=-344/233, 19-20=-50/557, 18-19=-4/1060, 17-18=-4/1060, 16-17=-363/531, 15-16=-717/0
 WEBS 3-24=-229/0, 6-20=-268/0, 13-16=-717/0, 1-25=-244/96, 4-24=-483/0, 5-20=-548/0, 4-23=-14/21, 5-22=0/44, 12-16=-1172/0, 7-20=-1173/0, 12-17=0/617, 7-19=0/631, 11-17=-245/0, 9-19=-224/15, 10-17=-259/162, 10-18=-111/60, 13-15=0/889, 2-25=-23/134, 2-24=-559/0

NOTES

1) Unbalanced floor live loads have been considered for this design.

- All plates are 3x4 (=) MT20 unless otherwise indicated.
- Attach ribbon block to truss with 3-10d nails applied to flat face.
- Refer to girder(s) for truss to truss connections.
- Provide mechanical connection (by others) of truss to bearing plate capable of withstanding 78 lb uplift at joint 26.
- Load case(s) 1, 3 has/have been modified. Building designer must review loads to verify that they are correct for the intended use of this truss.
- Recommend 2x6 strongbacks, on edge, spaced at 10-00-00 oc and fastened to each truss with 3-10d (0.131" X 3") nails. Strongbacks to be attached to walls at their outer ends or restrained by other means.
- CAUTION, Do not erect truss backwards.

LOAD CASE(S) Standard

- Dead + Floor Live (balanced): Lumber Increase=1.00, Plate Increase=1.00
 Uniform Loads (lb/ft)
 Vert: 15-26=-10, 1-14=-100
 Concentrated Loads (lb)
 Vert: 14=-370
- Dead + Snow (balanced): Lumber Increase=0.90, Plate Increase=0.90
 Uniform Loads (lb/ft)
 Vert: 15-26=-10, 1-14=-20
 Concentrated Loads (lb)
 Vert: 14=-500



November 4, 2025

WARNING - Verify design parameters and READ NOTES ON THIS AND INCLUDED MITEK REFERENCE PAGE MII-7473 rev. 1/2/2023 BEFORE USE.

Design valid for use only with MiTek® connectors. This design is based only upon parameters shown, and is for an individual building component, not a truss system. Before use, the building designer must verify the applicability of design parameters and properly incorporate this design into the overall building design. Bracing indicated is to prevent buckling of individual truss web and/or chord members only. Additional temporary and permanent bracing is always required for stability and to prevent collapse with possible personal injury and property damage. For general guidance regarding the fabrication, storage, delivery, erection and bracing of trusses and truss systems, see **ANSI/TPI1 Quality Criteria and DSB-22** available from Truss Plate Institute (www.tpinst.org) and **BCSI Building Component Safety Information** available from the Structural Building Component Association (www.sbcsccomponents.com)

MiTek®

400 Sunrise Ave., Suite 270
 Roseville, CA 95661
 916.755.3571 / MiTek-US.com

Job J1183948F2	Truss F10	Truss Type Floor	Qty 1	Ply 1	NW Eastside Builders LLC Job Reference (optional)	R91075023
-------------------	--------------	---------------------	----------	----------	--	-----------

The Truss Company (Sumner, WA), Sumner, WA - 98390,

Run: 25.30 S Oct 2 2025 Print: 25.3.0 S Oct 2 2025 MiTek Industries, Inc. Mon Nov 03 18:01:59
ID:BL3qPxV17x8JJ9dS16USLoz87XL-RfC?PsB70Hq3NSgPqnl8w3uITxbGKwRCDoi7J4zJC?f

Page: 1

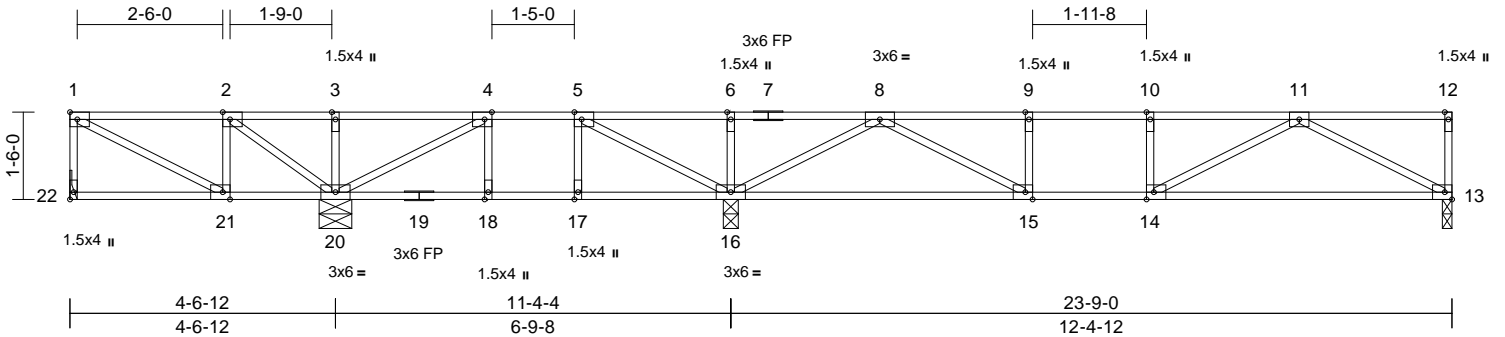

Scale = 1:39.6

Plate Offsets (X, Y): [2:0-1-8,Edge], [4:0-1-8,Edge], [5:0-1-8,Edge], [14:0-1-8,Edge], [15:0-1-8,Edge], [21:0-1-8,Edge], [22:Edge,0-0-12]

Loading	(psf)	Spacing	2-0-0	CSI	DEFL	in	(loc)	l/defl	L/d	PLATES	GRIP	
TCLL	40.0	Plate Grip DOL	1.00	TC	0.42	Vert(LL)	-0.13	13-14	>999	480	MT20	185/148
TCDL	10.0	Lumber DOL	1.00	BC	0.50	Vert(CT)	-0.21	13-14	>711	360		
BCLL	0.0	Rep Stress Incr	YES	WB	0.32	Horz(CT)	0.02	13	n/a	n/a		
BCDL	5.0	Code	IRC2021/TPI2014	Matrix-S							Weight: 104 lb	FT = 20%F, 11%E

LUMBER

TOP CHORD 2x4 HF-N No.1/No.2(flat)
BOT CHORD 2x4 HF-N No.1/No.2(flat)
WEBS 2x4 DF Stud(flat)

BRACING

TOP CHORD Structural wood sheathing directly applied or 6-0-0 oc purlins, except end verticals.
BOT CHORD Rigid ceiling directly applied or 6-0-0 oc bracing.

REACTIONS (size) 13=0-2-0, 16=0-3-1, 20=0-6-12, 22= Mechanical
Max Uplift 22=39 (LC 4)
Max Grav 13=642 (LC 11), 16=1121 (LC 12), 20=775 (LC 11), 22=219 (LC 14)

FORCES (lb) - Maximum Compression/Maximum Tension

TOP CHORD 1-22=-207/50, 12-13=-99/0, 1-2=-187/143, 2-3=0/491, 3-4=0/491, 4-5=-426/197, 5-6=-54/614, 6-8=-54/614, 8-9=-1352/0, 9-10=-1352/0, 10-11=-1352/0, 11-12=0/0
BOT CHORD 21-22=0/0, 20-21=-143/187, 18-20=-197/426, 17-18=-197/426, 16-17=-197/426, 15-16=0/771, 14-15=0/1352, 13-14=0/966
WEBS 3-20=-230/0, 6-16=-279/0, 2-20=-519/0, 4-20=-548/0, 5-16=-535/0, 4-18=-6/33, 5-17=0/38, 8-16=-1210/0, 11-13=-1096/0, 8-15=0/712, 11-14=0/439, 9-15=-283/0, 10-14=-181/0, 2-21=-74/97, 1-21=-161/211

NOTES

- 1) Unbalanced floor live loads have been considered for this design.
- 2) All plates are 3x4 (=) MT20 unless otherwise indicated.
- 3) Refer to girder(s) for truss to truss connections.
- 4) Provide mechanical connection (by others) of truss to bearing plate at joint(s) 13.
- 5) Provide mechanical connection (by others) of truss to bearing plate capable of withstanding 39 lb uplift at joint 22.

- 6) Recommend 2x6 strongbacks, on edge, spaced at 10-00-00 oc and fastened to each truss with 3-10d (0.131" X 3") nails. Strongbacks to be attached to walls at their outer ends or restrained by other means.
- 7) CAUTION, Do not erect truss backwards.

LOAD CASE(S) Standard



November 4, 2025

WARNING - Verify design parameters and READ NOTES ON THIS AND INCLUDED MITEK REFERENCE PAGE MII-7473 rev. 1/2/2023 BEFORE USE.

Design valid for use only with MiTek® connectors. This design is based only upon parameters shown, and is for an individual building component, not a truss system. Before use, the building designer must verify the applicability of design parameters and properly incorporate this design into the overall building design. Bracing indicated is to prevent buckling of individual truss web and/or chord members only. Additional temporary and permanent bracing is always required for stability and to prevent collapse with possible personal injury and property damage. For general guidance regarding the fabrication, storage, delivery, erection and bracing of trusses and truss systems, see **ANSI/TPI1 Quality Criteria and DSB-22** available from Truss Plate Institute (www.tpinst.org) and **BCSI Building Component Safety Information** available from the Structural Building Component Association (www.sbcsccomponents.com)

MiTek®

400 Sunrise Ave., Suite 270
Roseville, CA 95661
916.755.3571 / MiTek-US.com

Job J1183948F2	Truss F09	Truss Type Floor	Qty 3	Ply 1	NW Eastside Builders LLC Job Reference (optional)	R91075024
-------------------	--------------	---------------------	----------	----------	--	-----------

The Truss Company (Sumner, WA), Sumner, WA - 98390,

Run: 25.30 S Oct 2 2025 Print: 25.3.0 S Oct 2 2025 MiTek Industries, Inc. Mon Nov 03 18:01:59
ID:Fzx3_FUVcKtb4rT4vhS_GNz87XN-RfC?PsB70Hq3NSgPqnL8w3ulTXbGKWrCDoi7J4zJC?F

Page: 1

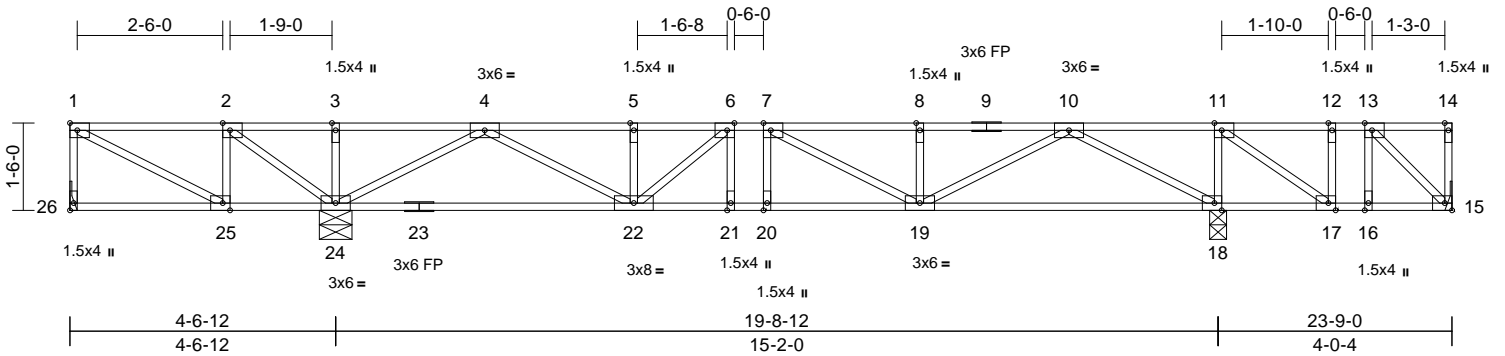

Scale = 1:39.6

Plate Offsets (X, Y): [2:0-1-8,Edge], [6:0-1-8,Edge], [7:0-1-8,Edge], [11:0-1-8,Edge], [13:0-1-8,Edge], [17:0-1-8,Edge], [18:0-1-8,Edge], [25:0-1-8,Edge], [26:Edge,0-0-12]

Loading	(psf)	Spacing	2-0-0	CSI	DEFL	in	(loc)	l/defl	L/d	PLATES	GRIP	
TCLL	40.0	Plate Grip DOL	1.00	TC	0.49	Vert(LL)	-0.07	19-20	>999	480	MT20	185/148
TCDL	10.0	Lumber DOL	1.00	BC	0.42	Vert(CT)	-0.10	19-20	>999	360		
BCLL	0.0	Rep Stress Incr	YES	WB	0.40	Horz(CT)	0.01	18	n/a	n/a		
BCDL	5.0	Code	IRC2021/TPI2014	Matrix-S								
											Weight: 112 lb	FT = 20%F, 11%E

LUMBER

TOP CHORD 2x4 HF-N No.1/No.2(flat)
BOT CHORD 2x4 HF-N No.1/No.2(flat)
WEBS 2x4 DF Stud(flat)

BRACING

TOP CHORD Structural wood sheathing directly applied or 6-0-0 oc purlins, except end verticals.
BOT CHORD Rigid ceiling directly applied or 6-0-0 oc bracing.

REACTIONS (size) 15= Mechanical, 18=0-3-8, 24=0-6-12, 26= Mechanical
Max Uplift 15=238 (LC 6), 26=286 (LC 6)
Max Grav 15=123 (LC 5), 18=1341 (LC 4), 24=1487 (LC 14), 26=137 (LC 5)

FORCES

(lb) - Maximum Compression/Maximum Tension
TOP CHORD 1-26=-124/298, 14-15=-98/0, 1-2=-33/613, 2-3=0/1160, 3-4=0/1160, 4-5=-1034/0, 5-6=-1034/0, 6-7=-1288/0, 7-8=-1163/0, 8-10=-1163/0, 10-11=0/874, 11-12=-45/332, 12-13=-45/332, 13-14=0/0
BOT CHORD 25-26=0/0, 24-25=-613/33, 22-24=-17/220, 21-22=0/1288, 20-21=0/1288, 19-20=0/1288, 18-19=0/435, 17-18=-874/0, 16-17=-332/45, 15-16=-332/45
WEBS 3-24=-206/0, 11-18=-655/0, 2-24=-863/0, 10-18=-1403/0, 4-24=-1521/0, 10-19=0/855, 4-22=0/942, 8-19=-285/0, 5-22=-232/0, 7-19=-299/78, 6-22=-433/0, 6-21=-44/148, 7-20=-125/48, 11-17=0/760, 13-15=-63/470, 12-17=-285/0, 13-16=-193/0, 2-25=-5/333, 1-25=-692/38

NOTES

- 1) Unbalanced floor live loads have been considered for this design.
- 2) All plates are 3x4 (=) MT20 unless otherwise indicated.
- 3) Refer to girder(s) for truss to truss connections.

- 4) Provide mechanical connection (by others) of truss to bearing plate capable of withstanding 286 lb uplift at joint 26 and 238 lb uplift at joint 15.
- 5) Recommend 2x6 strongbacks, on edge, spaced at 10-00-00 oc and fastened to each truss with 3-10d (0.131" X 3") nails. Strongbacks to be attached to walls at their outer ends or restrained by other means.
- 6) CAUTION, Do not erect truss backwards.

LOAD CASE(S) Standard



November 4, 2025

WARNING - Verify design parameters and READ NOTES ON THIS AND INCLUDED MITEK REFERENCE PAGE MII-7473 rev. 1/2/2023 BEFORE USE.

Design valid for use only with MiTek® connectors. This design is based only upon parameters shown, and is for an individual building component, not a truss system. Before use, the building designer must verify the applicability of design parameters and properly incorporate this design into the overall building design. Bracing indicated is to prevent buckling of individual truss web and/or chord members only. Additional temporary and permanent bracing is always required for stability and to prevent collapse with possible personal injury and property damage. For general guidance regarding the fabrication, storage, delivery, erection and bracing of trusses and truss systems, see **ANSI/TPI1 Quality Criteria and DSB-22** available from Truss Plate Institute (www.tpinst.org) and **BCSI Building Component Safety Information** available from the Structural Building Component Association (www.sbcsccomponents.com)

MiTek®

400 Sunrise Ave., Suite 270
Roseville, CA 95661
916.755.3571 / MiTek-US.com

Job J1183948F2	Truss F08	Truss Type Floor	Qty 2	Ply 1	NW Eastside Builders LLC Job Reference (optional)	R91075025
-------------------	--------------	---------------------	----------	----------	--	-----------

The Truss Company (Sumner, WA), Sumner, WA - 98390,

Run: 25.30 S Oct 2 2025 Print: 25.3.0 S Oct 2 2025 MiTek Industries, Inc. Mon Nov 03 18:01:59
ID:Fzx3_FUVcKtb4rT4vhS_GNz87XN-RfC?PsB70Hq3NSgPqnL8w3ulTXbGKWrCdoi7J4zJC?f

Page: 1

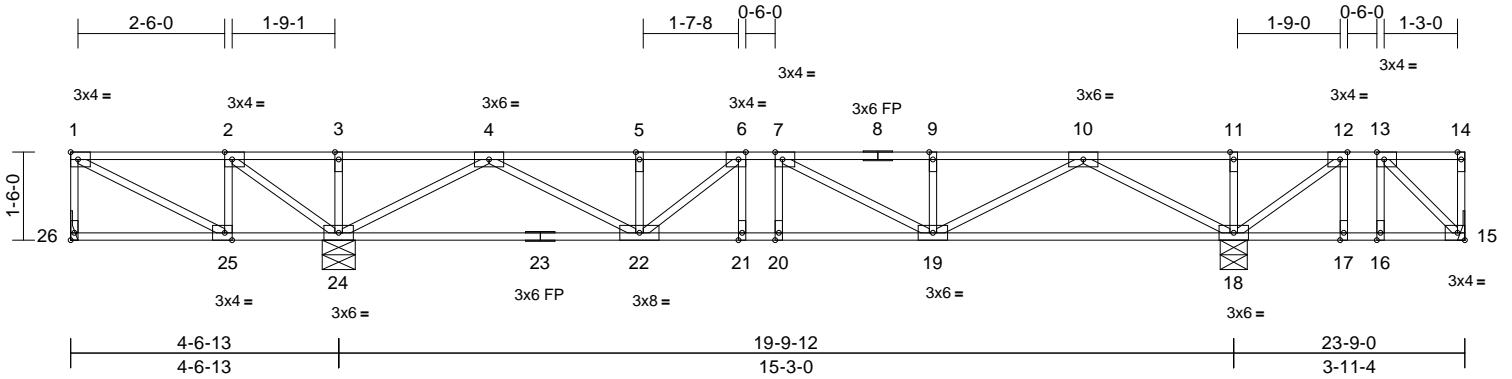

Scale = 1:39.3

Plate Offsets (X, Y): [2:0-1-8,Edge], [6:0-1-8,Edge], [7:0-1-8,Edge], [12:0-1-8,Edge], [13:0-1-8,Edge], [25:0-1-8,Edge], [26:Edge,0-0-12]

Loading	(psf)	Spacing	2-0-0	CSI	DEFL	in	(loc)	l/defl	L/d	PLATES	GRIP	
TCLL	40.0	Plate Grip DOL	1.00	TC	0.50	Vert(LL)	-0.08	19-20	>999	480	MT20	185/148
TCDL	10.0	Lumber DOL	1.00	BC	0.41	Vert(CT)	-0.10	19-20	>999	360		
BCLL	0.0	Rep Stress Incr	YES	WB	0.41	Horz(CT)	0.01	18	n/a	n/a		
BCDL	5.0	Code	IRC2021/TPI2014	Matrix-S								
											Weight: 112 lb	FT = 20%F, 11%E

LUMBER

TOP CHORD 2x4 HF-N No.1/No.2(flat)
BOT CHORD 2x4 HF-N No.1/No.2(flat)
WEBS 2x4 DF Stud(flat)

BRACING

TOP CHORD Structural wood sheathing directly applied or 6-0-0 oc purlins, except end verticals.
BOT CHORD Rigid ceiling directly applied or 6-0-0 oc bracing.

REACTIONS

(size) 15= Mechanical, 18=0-5-8, 24=0-6-12, 26= Mechanical
Max Uplift 15=252 (LC 6), 26=291 (LC 6)
Max Grav 15=115 (LC 5), 18=1353 (LC 4), 24=1496 (LC 14), 26=135 (LC 5)

FORCES

(lb) - Maximum Compression/Maximum Tension

TOP CHORD 1-26=-123/303, 14-15=-100/0, 1-2=-31/622, 2-3=0/1175, 3-4=0/1175, 4-5=-1035/0, 5-6=-1035/0, 6-7=-1300/0, 7-9=-1165/0, 9-10=-1165/0, 10-11=0/892, 11-12=0/892, 12-13=-35/348, 13-14=0/0
BOT CHORD 25-26=0/0, 24-25=-622/31, 22-24=-21/212, 21-22=0/1300, 20-21=0/1300, 19-20=0/1300, 18-19=0/428, 17-18=-348/35, 16-17=-348/35, 15-16=-348/35
WEBS 3-24=-207/0, 11-18=-217/0, 1-25=-703/35, 10-18=-1413/0, 4-24=-1530/0, 10-19=0/864, 4-22=0/953, 9-19=-285/0, 5-22=-235/0, 7-19=-308/71, 6-22=-437/0, 6-21=-46/146, 7-20=-124/52, 12-18=-767/0, 13-15=-49/492, 12-17=0/195, 13-16=-197/0, 2-25=-3/338, 2-24=-872/0

NOTES

- Unbalanced floor live loads have been considered for this design.
- All plates are 1.5x4 (I) MT20 unless otherwise indicated.
- Refer to girder(s) for truss to truss connections.

- Provide mechanical connection (by others) of truss to bearing plate capable of withstanding 291 lb uplift at joint 26 and 252 lb uplift at joint 15.
- Recommend 2x6 strongbacks, on edge, spaced at 10-00-00 oc and fastened to each truss with 3-10d (0.131" X 3") nails. Strongbacks to be attached to walls at their outer ends or restrained by other means.
- CAUTION, Do not erect truss backwards.

LOAD CASE(S) Standard



November 4, 2025

WARNING - Verify design parameters and READ NOTES ON THIS AND INCLUDED MITEK REFERENCE PAGE MII-7473 rev. 1/2/2023 BEFORE USE.

Design valid for use only with MiTek® connectors. This design is based only upon parameters shown, and is for an individual building component, not a truss system. Before use, the building designer must verify the applicability of design parameters and properly incorporate this design into the overall building design. Bracing indicated is to prevent buckling of individual truss web and/or chord members only. Additional temporary and permanent bracing is always required for stability and to prevent collapse with possible personal injury and property damage. For general guidance regarding the fabrication, storage, delivery, erection and bracing of trusses and truss systems, see **ANSI/TPI1 Quality Criteria and DSB-22** available from Truss Plate Institute (www.tpinst.org) and **BCSI Building Component Safety Information** available from the Structural Building Component Association (www.sbcsccomponents.com)

MiTek®

400 Sunrise Ave., Suite 270
Roseville, CA 95661
916.755.3571 / MiTek-US.com

Job J1183948F2	Truss F07	Truss Type Floor	Qty 2	Ply 1	NW Eastside Builders LLC Job Reference (optional)	R91075026
-------------------	--------------	---------------------	----------	----------	--	-----------

The Truss Company (Sumner, WA), Sumner, WA - 98390,

Run: 25.30 S Oct 2 2025 Print: 25.3.0 S Oct 2 2025 MiTek Industries, Inc. Mon Nov 03 18:01:59
ID:Fzx3_FUVcKtb4rT4vhS_GNz87XN-RfC?PsB70Hq3NSgPqnL8w3ulTXbGKWrCDoi7J4zJC?f

Page: 1

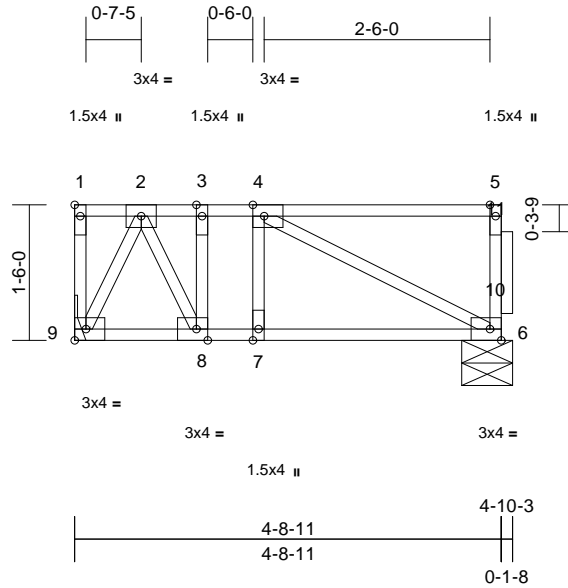

Scale = 1:25.5

Plate Offsets (X, Y): [1:Edge,0-0-12], [4:0-1-8,Edge], [8:0-1-8,Edge]

Loading	(psf)	Spacing	2-0-0	CSI	DEFL	in	(loc)	l/defl	L/d	PLATES	GRIP	
TCLL	40.0	Plate Grip DOL	1.00	TC	0.31	Vert(LL)	-0.02	6-7	>999	480	MT20	185/148
TCDL	10.0	Lumber DOL	1.00	BC	0.19	Vert(CT)	-0.02	6-7	>999	360		
BCLL	0.0	Rep Stress Incr	YES	WB	0.10	Horz(CT)	0.00	6	n/a	n/a		
BCDL	5.0	Code	IRC2021/TPI2014	Matrix-S							Weight: 27 lb	FT = 20%F, 11%E

LUMBER

TOP CHORD 2x4 HF-N No.1/No.2(flat)
 BOT CHORD 2x4 HF-N No.1/No.2(flat)
 WEBS 2x4 DF Stud(flat)
 OTHERS 2x4 DF Stud(flat)

BRACING

TOP CHORD Structural wood sheathing directly applied or 4-10-3 oc purlins, except end verticals.
 BOT CHORD Rigid ceiling directly applied or 10-0-0 oc bracing.

REACTIONS (size) 6=0-6-12, 9= Mechanical
 Max Grav 6=253 (LC 1), 9=253 (LC 1)

FORCES (lb) - Maximum Compression/Maximum Tension

TOP CHORD 1-9=-39/0, 5-6=-114/0, 1-2=0/0, 2-3=-229/0, 3-4=-229/0, 4-5=0/0
 BOT CHORD 8-9=0/114, 7-8=0/229, 6-7=0/229
 WEBS 4-6=-258/0, 2-9=-259/0, 2-8=0/264, 3-8=-117/0, 4-7=-80/8

NOTES

- 1) Unbalanced floor live loads have been considered for this design.
- 2) Attach ribbon block to truss with 3-10d nails applied to flat face.
- 3) Refer to girder(s) for truss to truss connections.
- 4) Recommend 2x6 strongbacks, on edge, spaced at 10-00-00 oc and fastened to each truss with 3-10d (0.131" X 3") nails. Strongbacks to be attached to walls at their outer ends or restrained by other means.
- 5) CAUTION, Do not erect truss backwards.

LOAD CASE(S) Standard



November 4, 2025

WARNING - Verify design parameters and READ NOTES ON THIS AND INCLUDED MITEK REFERENCE PAGE MII-7473 rev. 1/2/2023 BEFORE USE.

Design valid for use only with MiTek® connectors. This design is based only upon parameters shown, and is for an individual building component, not a truss system. Before use, the building designer must verify the applicability of design parameters and properly incorporate this design into the overall building design. Bracing indicated is to prevent buckling of individual truss web and/or chord members only. Additional temporary and permanent bracing is always required for stability and to prevent collapse with possible personal injury and property damage. For general guidance regarding the fabrication, storage, delivery, erection and bracing of trusses and truss systems, see **ANSI/TPI1 Quality Criteria and DSB-22** available from Truss Plate Institute (www.tpinst.org) and **BCSI Building Component Safety Information** available from the Structural Building Component Association (www.sbcsccomponents.com)

MiTek®

400 Sunrise Ave., Suite 270
 Roseville, CA 95661
 916.755.3571 / MiTek-US.com

Job J1183948F2	Truss F06	Truss Type Floor Supported Gable	Qty 1	Ply 1	NW Eastside Builders LLC Job Reference (optional)	R91075027
-------------------	--------------	-------------------------------------	----------	----------	--	-----------

The Truss Company (Sumner, WA), Sumner, WA - 98390,

Run: 25.30 S Oct 2 2025 Print: 25.3.0 S Oct 2 2025 MiTek Industries, Inc. Mon Nov 03 18:01:59
ID:Fzx3_FUVcKt4rT4vhS_GNz87XN-RfC?PsB70Hq3NSgPqnL8w3uTXbGKWrCDoi7J4zJC?f

Page: 1

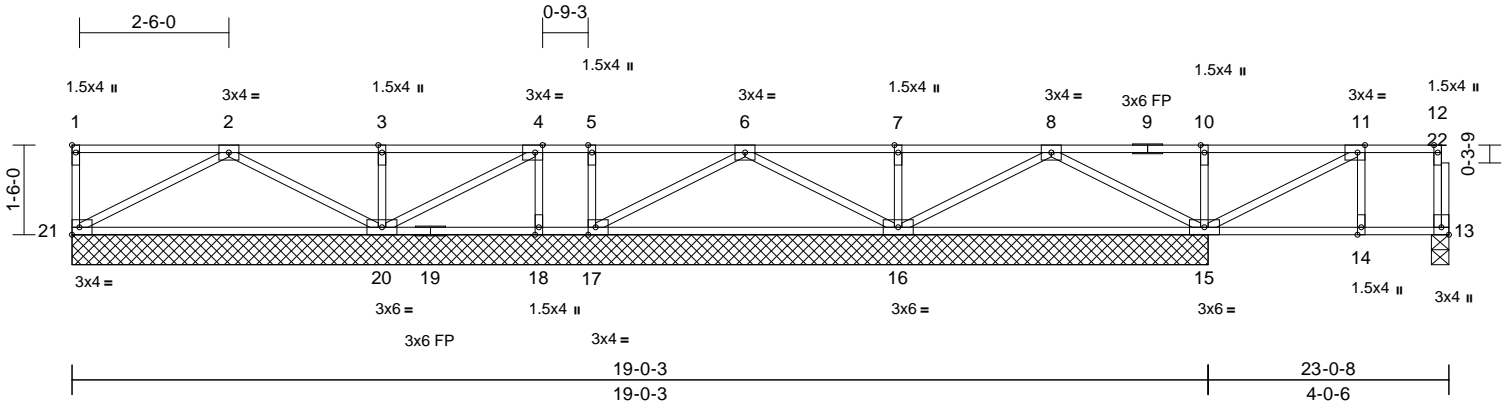

Scale = 1:38.6

Plate Offsets (X, Y): [1:Edge,0-0-12], [4:0-1-8,Edge], [11:0-1-8,Edge], [13:Edge,0-1-8], [17:0-1-8,Edge]

Loading	(psf)	Spacing	2-0-0	CSI	DEFL	in	(loc)	l/defl	L/d	PLATES	GRIP	
TCLL	40.0	Plate Grip DOL	1.00	TC	0.34	Vert(LL)	-0.01	14-15	>999	480	MT20	185/148
TCDL	10.0	Lumber DOL	1.00	BC	0.17	Vert(CT)	-0.06	20-21	>999	360		
BCLL	0.0	Rep Stress Incr	YES	WB	0.13	Horz(CT)	0.00	13	n/a	n/a		
BCDL	5.0	Code	IRC2021/TPI2014	Matrix-S							Weight: 103 lb	FT = 20%F, 11%E

LUMBER

TOP CHORD 2x4 HF-N No.1/No.2(flat)
 BOT CHORD 2x4 HF-N No.1/No.2(flat)
 WEBS 2x4 DF Stud(flat)
 OTHERS 2x4 DF Stud(flat)

- 3) Recommend 2x6 strongbacks, on edge, spaced at 10-00-00 oc and fastened to each truss with 3-10d (0.131" X 3") nails. Strongbacks to be attached to walls at their outer ends or restrained by other means.
- 4) CAUTION, Do not erect truss backwards.

BRACING

TOP CHORD Structural wood sheathing directly applied or 6-0-0 oc purlins, except end verticals.
 BOT CHORD Rigid ceiling directly applied or 6-0-0 oc bracing.

LOAD CASE(S) Standard

REACTIONS (size) 13=0-3-8, 15=19-0-3, 16=19-0-3, 17=19-0-3, 18=19-0-3, 20=19-0-3, 21=19-0-3
 Max Grav 13=70 (LC 10), 15=733 (LC 1), 16=598 (LC 3), 17=336 (LC 3), 18=141 (LC 3), 20=494 (LC 3), 21=243 (LC 3)

FORCES (lb) - Maximum Compression/Maximum Tension

TOP CHORD 1-21=-102/0, 12-13=-61/0, 1-2=0/0, 2-3=0/86, 3-4=0/86, 4-5=0/66, 5-6=0/66, 6-7=0/133, 7-8=0/133, 8-10=0/423, 10-11=0/423, 11-12=-3/0
 BOT CHORD 20-21=0/223, 18-20=-66/0, 17-18=-66/0, 16-17=0/156, 15-16=-204/152, 14-15=0/3, 13-14=0/3
 WEBS 10-15=-278/0, 8-15=-414/0, 2-21=-253/0, 8-16=-305/182, 2-20=-350/0, 7-16=-258/0, 3-20=-263/0, 6-16=-317/0, 4-20=-22/0, 6-17=-251/0, 4-18=-161/0, 5-17=-163/0, 11-15=-479/0, 11-14=-1/14

NOTES

- 1) Unbalanced floor live loads have been considered for this design.
- 2) Attach ribbon block to truss with 3-10d nails applied to flat face.



November 4, 2025

WARNING - Verify design parameters and READ NOTES ON THIS AND INCLUDED MITEK REFERENCE PAGE MII-7473 rev. 1/2/2023 BEFORE USE.

Design valid for use only with MiTek® connectors. This design is based only upon parameters shown, and is for an individual building component, not a truss system. Before use, the building designer must verify the applicability of design parameters and properly incorporate this design into the overall building design. Bracing indicated is to prevent buckling of individual truss web and/or chord members only. Additional temporary and permanent bracing is always required for stability and to prevent collapse with possible personal injury and property damage. For general guidance regarding the fabrication, storage, delivery, erection and bracing of trusses and truss systems, see **ANSI/TPI1 Quality Criteria and DSB-22** available from Truss Plate Institute (www.tpinst.org) and **BCSI Building Component Safety Information** available from the Structural Building Component Association (www.sbcsccomponents.com)

MiTek®

400 Sunrise Ave., Suite 270
 Roseville, CA 95661
 916.755.3571 / MiTek-US.com

Job J1183948F2	Truss F05	Truss Type Floor	Qty 1	Ply 1	NW Eastside Builders LLC Job Reference (optional)	R91075028
-------------------	--------------	---------------------	----------	----------	--	-----------

The Truss Company (Sumner, WA), Sumner, WA - 98390,

Run: 25.30 S Oct 2 2025 Print: 25.3.0 S Oct 2 2025 MiTek Industries, Inc. Mon Nov 03 18:01:59
ID:Fzx3_FUVcKt4rT4vhS_GNz87XN-RfC?PsB70Hq3NSgPqnL8w3ulTXbGKWrCDoi7J4zJC?f

Page: 1

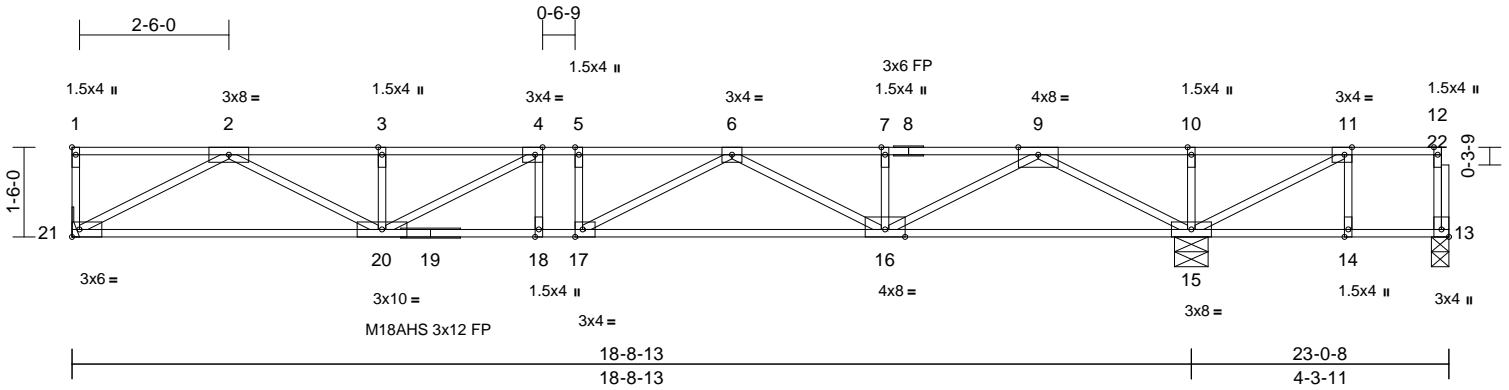

Scale = 1:38.6

Plate Offsets (X, Y): [1:Edge,0-0-12], [4:0-1-8,Edge], [11:0-1-8,Edge], [13:Edge,0-1-8], [17:0-1-8,Edge]

Loading	(psf)	Spacing	2-0-0	CSI	DEFL	in	(loc)	l/defl	L/d	PLATES	GRIP	
TCLL	40.0	Plate Grip DOL	1.00	TC	0.55	Vert(LL)	-0.24	16-17	>921	480	M18AHS	145/140
TCDL	10.0	Lumber DOL	1.00	BC	0.87	Vert(CT)	-0.35	16-17	>636	360	MT20	185/148
BCLL	0.0	Rep Stress Incr	YES	WB	0.55	Horz(CT)	0.06	15	n/a	n/a		
BCDL	5.0	Code	IRC2021/TPI2014	Matrix-S								
											Weight: 103 lb	FT = 20%F, 11%E

LUMBER

TOP CHORD 2x4 HF-N No.1/No.2(flat)
 BOT CHORD 2x4 HF-N No.1/No.2(flat)
 WEBS 2x4 DF Stud(flat)
 OTHERS 2x4 DF Stud(flat)

BRACING

TOP CHORD Structural wood sheathing directly applied or 6-0-0 oc purlins, except end verticals.
 BOT CHORD Rigid ceiling directly applied or 6-0-0 oc bracing.

REACTIONS (size) 13=0-3-8, 15=0-6-12, 21= Mechanical
 Max Uplift 13=-73 (LC 3)
 Max Grav 13=44 (LC 4), 15=1560 (LC 1), 21=997 (LC 3)

FORCES (lb) - Maximum Compression/Maximum Tension

TOP CHORD 1-21=-104/0, 12-13=-38/36, 1-2=0/0, 2-3=-2707/0, 3-4=-2707/0, 4-5=-3268/0, 5-6=-3268/0, 6-7=-2529/0, 7-9=-2529/0, 9-10=0/709, 10-11=0/709, 11-12=-2/2
 BOT CHORD 20-21=0/1624, 18-20=0/3268, 17-18=0/3268, 16-17=0/3163, 15-16=-29/1330, 14-15=-2/2, 13-14=-2/2
 WEBS 10-15=-246/0, 9-15=-1971/0, 2-21=-1843/0, 9-16=0/1420, 2-20=0/1229, 7-16=-248/0, 3-20=-275/0, 6-16=-773/0, 4-20=-706/0, 6-17=-146/499, 4-18=-111/121, 5-17=-100/0, 11-15=-801/0, 11-14=0/90

NOTES

- 1) Unbalanced floor live loads have been considered for this design.
- 2) All plates are MT20 plates unless otherwise indicated.
- 3) Attach ribbon block to truss with 3-10d nails applied to flat face.
- 4) Refer to girder(s) for truss to truss connections.

- 5) Provide mechanical connection (by others) of truss to bearing plate capable of withstanding 73 lb uplift at joint 13.
- 6) Recommend 2x6 strongbacks, on edge, spaced at 10-00-00 oc and fastened to each truss with 3-10d (0.131" X 3") nails. Strongbacks to be attached to walls at their outer ends or restrained by other means.
- 7) CAUTION, Do not erect truss backwards.

LOAD CASE(S) Standard



November 4, 2025

WARNING - Verify design parameters and READ NOTES ON THIS AND INCLUDED MITEK REFERENCE PAGE MII-7473 rev. 1/2/2023 BEFORE USE.

Design valid for use only with MiTek® connectors. This design is based only upon parameters shown, and is for an individual building component, not a truss system. Before use, the building designer must verify the applicability of design parameters and properly incorporate this design into the overall building design. Bracing indicated is to prevent buckling of individual truss web and/or chord members only. Additional temporary and permanent bracing is always required for stability and to prevent collapse with possible personal injury and property damage. For general guidance regarding the fabrication, storage, delivery, erection and bracing of trusses and truss systems, see **ANSI/TPI1 Quality Criteria and DSB-22** available from Truss Plate Institute (www.tpinst.org) and **BCSI Building Component Safety Information** available from the Structural Building Component Association (www.sbcsccomponents.com)

MiTek®

400 Sunrise Ave., Suite 270
 Roseville, CA 95661
 916.755.3571 / MiTek-US.com

Job J1183948F2	Truss F04	Truss Type Floor	Qty 10	Ply 1	NW Eastside Builders LLC Job Reference (optional)	R91075029
-------------------	--------------	---------------------	-----------	----------	--	-----------

The Truss Company (Sumner, WA), Sumner, WA - 98390,

Run: 25.30 S Oct 2 2025 Print: 25.3.0 S Oct 2 2025 MiTek Industries, Inc. Mon Nov 03 18:01:58
ID:nmNhnvTr0lkShutLzWj9z87XO-RfC?PsB70Hq3NSgPqnL8w3ulTXbGKWrCDoi7J4zJC?f

Page: 1

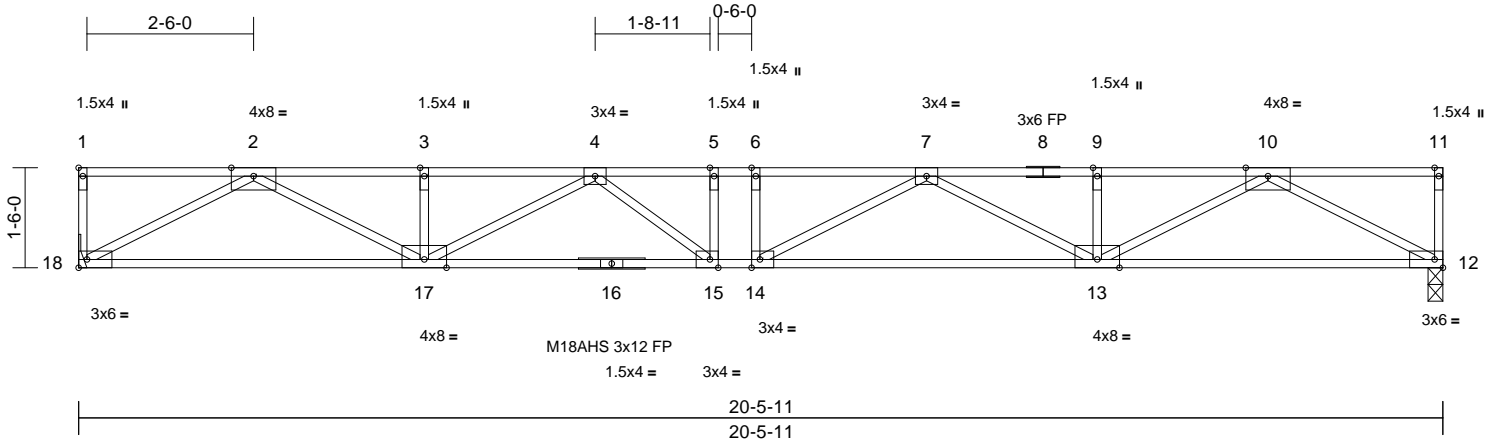

Scale = 1:34.6

Plate Offsets (X, Y): [1:Edge,0-0-12], [14:0-1-8,Edge], [15:0-1-8,Edge]

Loading	(psf)	Spacing	2-0-0	CSI	DEFL	in	(loc)	l/defl	L/d	PLATES	GRIP	
TCLL	40.0	Plate Grip DOL	1.00	TC	0.54	Vert(LL)	-0.33	13-14	>738	480	M18AHS	145/140
TCDL	10.0	Lumber DOL	1.00	BC	0.97	Vert(CT)	-0.47	13-14	>523	360	MT20	185/148
BCLL	0.0	Rep Stress Incr	YES	WB	0.57	Horz(CT)	0.09	12	n/a	n/a		
BCDL	5.0	Code	IRC2021/TPI2014	Matrix-S							Weight: 92 lb	FT = 20%F, 11%E

LUMBER **LOAD CASE(S)** Standard

TOP CHORD 2x4 HF-N No.1/No.2(flat)
 BOT CHORD 2x4 HF-N No.1/No.2(flat) *Except* 16-12:2x4
 DF 1800F 1.6E or 2x4 DF No.1&Btr or 2x4
 DF-N 1800F 1.6E(flat)
 WEBS 2x4 DF Stud(flat)

BRACING
 TOP CHORD Structural wood sheathing directly applied or
 5-9-0 oc purlins, except end verticals.
 BOT CHORD Rigid ceiling directly applied or 10-0-0 oc
 bracing, Except:
 2-2-0 oc bracing: 15-17.

REACTIONS (size) 12=0-2-11, 18= Mechanical
 Max Grav 12=1119 (LC 1), 18=1119 (LC 1)

FORCES (lb) - Maximum Compression/Maximum
 Tension
 TOP CHORD 1-18=-103/0, 11-12=-102/0, 1-2=0/0,
 2-3=-3167/0, 3-4=-3167/0, 4-5=-4147/0,
 5-6=-4147/0, 6-7=-4147/0, 7-9=-3168/0,
 9-10=-3168/0, 10-11=0/0
 BOT CHORD 17-18=0/1852, 15-17=0/3911, 14-15=0/4147,
 13-14=0/3918, 12-13=0/1856
 WEBS 10-12=-2106/0, 2-18=-2101/0, 10-13=0/1489,
 2-17=0/1493, 9-13=-240/0, 3-17=-255/0,
 7-13=-852/0, 4-17=-844/0, 7-14=-157/554,
 4-15=-117/554, 5-15=-215/19, 6-14=-164/0

- NOTES**
- 1) Unbalanced floor live loads have been considered for this design.
 - 2) All plates are MT20 plates unless otherwise indicated.
 - 3) The Fabrication Tolerance at joint 16 = 11%
 - 4) Refer to girder(s) for truss to truss connections.
 - 5) Provide mechanical connection (by others) of truss to bearing plate at joint(s) 12.
 - 6) Recommend 2x6 strongbacks, on edge, spaced at 10-00-00 oc and fastened to each truss with 3-10d (0.131" X 3") nails. Strongbacks to be attached to walls at their outer ends or restrained by other means.



November 4, 2025

WARNING - Verify design parameters and READ NOTES ON THIS AND INCLUDED MITEK REFERENCE PAGE MII-7473 rev. 1/2/2023 BEFORE USE.

Design valid for use only with MiTek® connectors. This design is based only upon parameters shown, and is for an individual building component, not a truss system. Before use, the building designer must verify the applicability of design parameters and properly incorporate this design into the overall building design. Bracing indicated is to prevent buckling of individual truss web and/or chord members only. Additional temporary and permanent bracing is always required for stability and to prevent collapse with possible personal injury and property damage. For general guidance regarding the fabrication, storage, delivery, erection and bracing of trusses and truss systems, see **ANSI/TPI1 Quality Criteria and DSB-22** available from Truss Plate Institute (www.tpinst.org) and **BCSI Building Component Safety Information** available from the Structural Building Component Association (www.sbcsccomponents.com)

MiTek®

400 Sunrise Ave., Suite 270
 Roseville, CA 95661
 916.755.3571 / MiTek-US.com

Job J1183948F2	Truss F03	Truss Type Floor	Qty 2	Ply 1	NW Eastside Builders LLC Job Reference (optional)	R91075030
-------------------	--------------	---------------------	----------	----------	--	-----------

The Truss Company (Sumner, WA), Sumner, WA - 98390,

Run: 25.30 S Oct 2 2025 Print: 25.3.0 S Oct 2 2025 MiTek Industries, Inc. Mon Nov 03 18:01:58
ID:j9VRCbU7Nd?Sh?2GTOzDoaz87XM-RfC?PsB70Hq3NSgPqL8w3uITXbGKWrCDoi7J4zJC?f

Page: 1

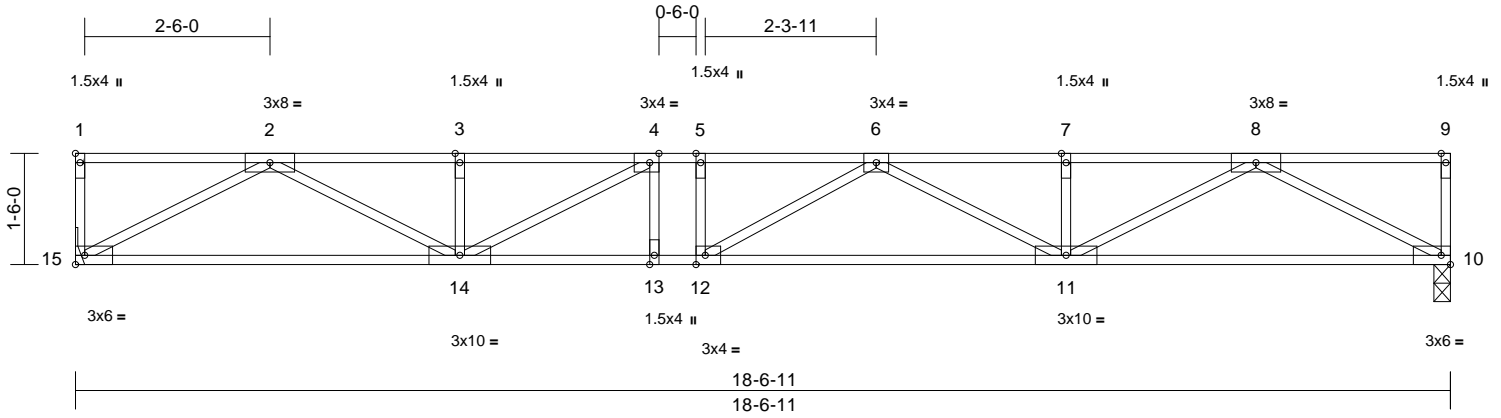

Scale = 1:31.1

Plate Offsets (X, Y): [1:Edge,0-0-12], [4:0-1-8,Edge], [12:0-1-8,Edge]

Loading	(psf)	Spacing	2-0-0	CSI	DEFL	in	(loc)	l/defl	L/d	PLATES	GRIP	
TCLL	40.0	Plate Grip DOL	1.00	TC	0.41	Vert(LL)	-0.24	11-12	>920	480	MT20	185/148
TCDL	10.0	Lumber DOL	1.00	BC	0.90	Vert(CT)	-0.35	11-12	>634	360		
BCLL	0.0	Rep Stress Incr	YES	WB	0.50	Horz(CT)	0.07	10	n/a	n/a		
BCDL	5.0	Code	IRC2021/TPI2014	Matrix-S							Weight: 83 lb	FT = 20%F, 11%E

LUMBER

TOP CHORD 2x4 HF-N No.1/No.2(flat)
BOT CHORD 2x4 HF-N No.1/No.2(flat)
WEBS 2x4 DF Stud(flat)

BRACING

TOP CHORD Structural wood sheathing directly applied or 6-0-0 oc purlins, except end verticals.
BOT CHORD Rigid ceiling directly applied or 10-0-0 oc bracing.

REACTIONS (size) 10=0-2-11, 15= Mechanical
Max Grav 10=1014 (LC 1), 15=1014 (LC 1)

FORCES (lb) - Maximum Compression/Maximum Tension

TOP CHORD 1-15=-103/0, 9-10=-102/0, 1-2=0/0,
2-3=-2770/0, 3-4=-2770/0, 4-5=-3363/0,
5-6=-3363/0, 6-7=-2777/0, 7-8=-2777/0,
8-9=0/0
BOT CHORD 14-15=0/1656, 13-14=0/3363, 12-13=0/3363,
11-12=0/3329, 10-11=0/1659
WEBS 8-10=-1883/0, 2-15=-1879/0, 8-11=0/1268,
2-14=0/1265, 7-11=-242/0, 3-14=-270/0,
6-11=-626/0, 4-14=-793/0, 6-12=-264/368,
4-13=-92/134, 5-12=-69/42

NOTES

- 1) Unbalanced floor live loads have been considered for this design.
- 2) Refer to girder(s) for truss to truss connections.
- 3) Provide mechanical connection (by others) of truss to bearing plate at joint(s) 10.
- 4) Recommend 2x6 strongbacks, on edge, spaced at 10-00-00 oc and fastened to each truss with 3-10d (0.131" X 3") nails. Strongbacks to be attached to walls at their outer ends or restrained by other means.

LOAD CASE(S) Standard



November 4, 2025

WARNING - Verify design parameters and READ NOTES ON THIS AND INCLUDED MITEK REFERENCE PAGE MII-7473 rev. 1/2/2023 BEFORE USE.

Design valid for use only with MiTek® connectors. This design is based only upon parameters shown, and is for an individual building component, not a truss system. Before use, the building designer must verify the applicability of design parameters and properly incorporate this design into the overall building design. Bracing indicated is to prevent buckling of individual truss web and/or chord members only. Additional temporary and permanent bracing is always required for stability and to prevent collapse with possible personal injury and property damage. For general guidance regarding the fabrication, storage, delivery, erection and bracing of trusses and truss systems, see **ANSI/TPI1 Quality Criteria and DSB-22** available from Truss Plate Institute (www.tpinst.org) and **BCSI Building Component Safety Information** available from the Structural Building Component Association (www.sbcsccomponents.com)

MiTek®

400 Sunrise Ave., Suite 270
Roseville, CA 95661
916.755.3571 / MiTek-US.com

Job J1183948F2	Truss F02	Truss Type Floor	Qty 3	Ply 1	NW Eastside Builders LLC Job Reference (optional)	R91075031
-------------------	--------------	---------------------	----------	----------	--	-----------

The Truss Company (Sumner, WA), Sumner, WA - 98390,

Run: 25.30 S Oct 2 2025 Print: 25.3.0 S Oct 2 2025 MiTek Industries, Inc. Mon Nov 03 18:01:58
ID:j9VRCbU7Nd?Sh?2GTOzDoaz87XM-RfC?PsB70Hq3NSgPqnL8w3uITXbGKWrCDoi7J4zJC?f

Page: 1

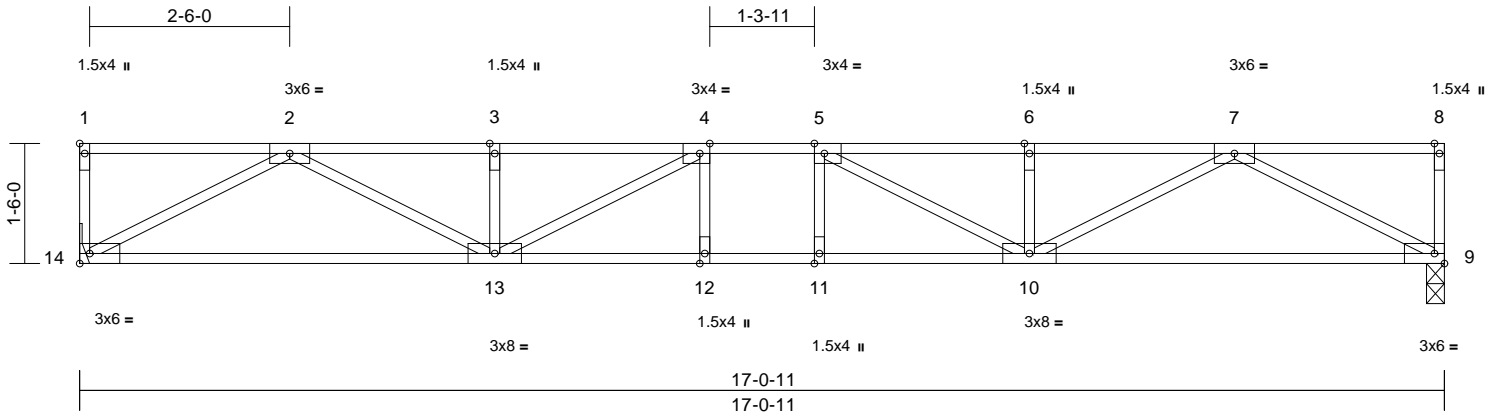

Scale = 1:28.8

Plate Offsets (X, Y): [1:Edge,0-0-12], [4:0-1-8,Edge], [5:0-1-8,Edge]

Loading	(psf)	Spacing	2-0-0	CSI	DEFL	in	(loc)	l/defl	L/d	PLATES	GRIP	
TCLL	40.0	Plate Grip DOL	1.00	TC	0.45	Vert(LL)	-0.17	11-12	>999	480	MT20	185/148
TCDL	10.0	Lumber DOL	1.00	BC	0.78	Vert(CT)	-0.23	11-12	>883	360		
BCLL	0.0	Rep Stress Incr	YES	WB	0.45	Horz(CT)	0.05	9	n/a	n/a		
BCDL	5.0	Code	IRC2021/TPI2014	Matrix-S							Weight: 75 lb	FT = 20%F, 11%E

LUMBER

TOP CHORD 2x4 HF-N No.1/No.2(flat)
 BOT CHORD 2x4 HF-N No.1/No.2(flat)
 WEBS 2x4 DF Stud(flat)

BRACING

TOP CHORD Structural wood sheathing directly applied or 6-0-0 oc purlins, except end verticals.
 BOT CHORD Rigid ceiling directly applied or 10-0-0 oc bracing.

REACTIONS (size) 9=0-2-11, 14= Mechanical
 Max Grav 9=931 (LC 1), 14=931 (LC 1)

FORCES (lb) - Maximum Compression/Maximum Tension

TOP CHORD 1-14=-104/0, 8-9=-104/0, 1-2=0/0,
 2-3=-2471/0, 3-4=-2471/0, 4-5=-2865/0,
 5-6=-2471/0, 6-7=-2471/0, 7-8=0/0
 BOT CHORD 13-14=0/1502, 12-13=0/2865, 11-12=0/2865,
 10-11=0/2865, 9-10=0/1502
 WEBS 7-9=-1705/0, 2-14=-1705/0, 7-10=0/1100,
 2-13=0/1100, 6-10=-295/0, 3-13=-295/0,
 5-10=-654/0, 4-13=-654/0, 4-12=-97/118,
 5-11=-97/118

NOTES

- 1) Unbalanced floor live loads have been considered for this design.
- 2) Refer to girder(s) for truss to truss connections.
- 3) Provide mechanical connection (by others) of truss to bearing plate at joint(s) 9.
- 4) Recommend 2x6 strongbacks, on edge, spaced at 10-00-00 oc and fastened to each truss with 3-10d (0.131" X 3") nails. Strongbacks to be attached to walls at their outer ends or restrained by other means.

LOAD CASE(S) Standard



November 4, 2025

WARNING - Verify design parameters and READ NOTES ON THIS AND INCLUDED MITEK REFERENCE PAGE MII-7473 rev. 1/2/2023 BEFORE USE.

Design valid for use only with MiTek® connectors. This design is based only upon parameters shown, and is for an individual building component, not a truss system. Before use, the building designer must verify the applicability of design parameters and properly incorporate this design into the overall building design. Bracing indicated is to prevent buckling of individual truss web and/or chord members only. Additional temporary and permanent bracing is always required for stability and to prevent collapse with possible personal injury and property damage. For general guidance regarding the fabrication, storage, delivery, erection and bracing of trusses and truss systems, see **ANSI/TPI1 Quality Criteria and DSB-22** available from Truss Plate Institute (www.tpinst.org) and **BCSI Building Component Safety Information** available from the Structural Building Component Association (www.sbcsccomponents.com)

MiTek®

400 Sunrise Ave., Suite 270
 Roseville, CA 95661
 916.755.3571 / MiTek-US.com

Job J1183948F2	Truss F01	Truss Type Floor Supported Gable	Qty 1	Ply 1	NW Eastside Builders LLC Job Reference (optional)	R91075032
-------------------	--------------	-------------------------------------	----------	----------	--	-----------

The Truss Company (Sumner, WA), Sumner, WA - 98390,

Run: 25.30 S Oct 2 2025 Print: 25.3.0 S Oct 2 2025 MiTek Industries, Inc. Mon Nov 03 18:01:57
ID:nmNhnvTtr0lkShutLzWj9z87XO-RfC?PsB70Hq3NSgPqnL8w3uITXbGKWrCDoi7J4zJC?f

Page: 1

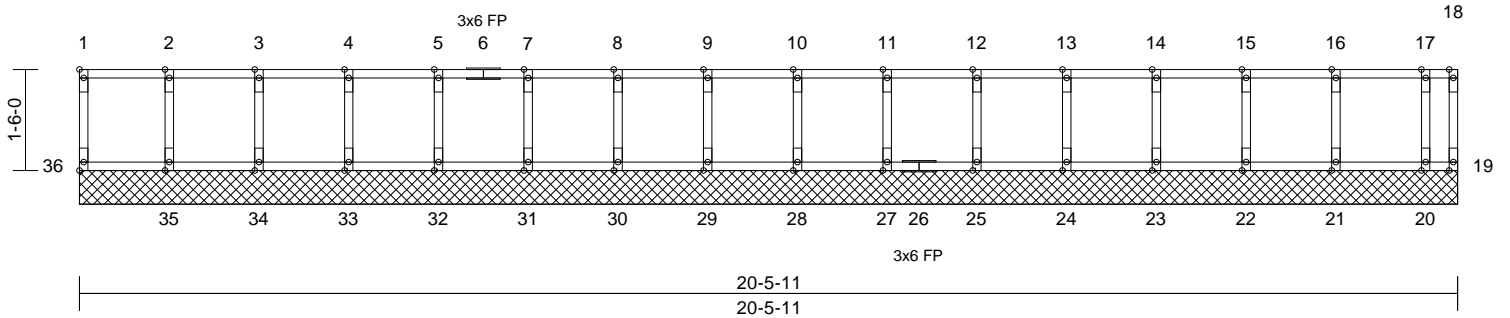

Scale = 1:34.2

Plate Offsets (X, Y): [1:Edge,0-0-12], [36:Edge,0-0-12]

Loading	(psf)	Spacing	2-0-0	CSI	DEFL	in	(loc)	l/defl	L/d	PLATES	GRIP	
TCLL	40.0	Plate Grip DOL	1.00	TC	0.06	Vert(LL)	n/a	-	n/a	999	MT20	185/148
TCDL	10.0	Lumber DOL	1.00	BC	0.01	Vert(TL)	n/a	-	n/a	999		
BCLL	0.0	Rep Stress Incr	YES	WB	0.03	Horiz(TL)	0.00	19	n/a	n/a		
BCDL	5.0	Code	IRC2021/TPI2014	Matrix-R							Weight: 80 lb	FT = 20%F, 11%E

LUMBER
TOP CHORD 2x4 HF-N No.1/No.2(flat)
BOT CHORD 2x4 HF-N No.1/No.2(flat)
WEBS 2x4 DF Stud(flat)
OTHERS 2x4 DF Stud(flat)

WEBS
2-35=-141/0, 3-34=-132/0, 4-33=-134/0,
5-32=-133/0, 7-31=-133/0, 8-30=-133/0,
9-29=-133/0, 10-28=-133/0, 11-27=-133/0,
12-25=-133/0, 13-24=-133/0, 14-23=-134/0,
15-22=-132/0, 16-21=-139/0, 17-20=-102/0

BRACING
TOP CHORD Structural wood sheathing directly applied or 6-0-0 oc purlins, except end verticals.
BOT CHORD Rigid ceiling directly applied or 10-0-0 oc bracing.

NOTES
1) All plates are 1.5x4 (||) MT20 unless otherwise indicated.
2) Gable requires continuous bottom chord bearing.
3) Truss to be fully sheathed from one face or securely braced against lateral movement (i.e. diagonal web).
4) Gable studs spaced at 1-4-0 oc.
5) Recommend 2x6 strongbacks, on edge, spaced at 10-00-00 oc and fastened to each truss with 3-10d (0.131" X 3") nails. Strongbacks to be attached to walls at their outer ends or restrained by other means.

REACTIONS (size)
19=20-5-11, 20=20-5-11,
21=20-5-11, 22=20-5-11,
23=20-5-11, 24=20-5-11,
25=20-5-11, 27=20-5-11,
28=20-5-11, 29=20-5-11,
30=20-5-11, 31=20-5-11,
32=20-5-11, 33=20-5-11,
34=20-5-11, 35=20-5-11,
36=20-5-11
Max Grav 19=8 (LC 1), 20=106 (LC 1),
21=153 (LC 1), 22=145 (LC 1),
23=147 (LC 1), 24=147 (LC 1),
25=147 (LC 1), 27=147 (LC 1),
28=147 (LC 1), 29=147 (LC 1),
30=147 (LC 1), 31=147 (LC 1),
32=147 (LC 1), 33=147 (LC 1),
34=145 (LC 1), 35=155 (LC 1),
36=60 (LC 1)

LOAD CASE(S) Standard

FORCES (lb) - Maximum Compression/Maximum Tension
TOP CHORD 1-36=-54/0, 18-19=-2/0, 1-2=-4/0, 2-3=-4/0,
3-4=-4/0, 4-5=-4/0, 5-7=-4/0, 7-8=-4/0,
8-9=-4/0, 9-10=-4/0, 10-11=-4/0, 11-12=-4/0,
12-13=-4/0, 13-14=-4/0, 14-15=-4/0,
15-16=-4/0, 16-17=-4/0, 17-18=-4/0
BOT CHORD 35-36=0/4, 34-35=0/4, 33-34=0/4, 32-33=0/4,
31-32=0/4, 30-31=0/4, 29-30=0/4, 28-29=0/4,
27-28=0/4, 25-27=0/4, 24-25=0/4, 23-24=0/4,
22-23=0/4, 21-22=0/4, 20-21=0/4, 19-20=0/4



November 4, 2025

WARNING - Verify design parameters and READ NOTES ON THIS AND INCLUDED MITEK REFERENCE PAGE MII-7473 rev. 1/2/2023 BEFORE USE.

Design valid for use only with MiTek® connectors. This design is based only upon parameters shown, and is for an individual building component, not a truss system. Before use, the building designer must verify the applicability of design parameters and properly incorporate this design into the overall building design. Bracing indicated is to prevent buckling of individual truss web and/or chord members only. Additional temporary and permanent bracing is always required for stability and to prevent collapse with possible personal injury and property damage. For general guidance regarding the fabrication, storage, delivery, erection and bracing of trusses and truss systems, see **ANSI/TPI1 Quality Criteria and DSB-22** available from Truss Plate Institute (www.tpinst.org) and **BCSI Building Component Safety Information** available from the Structural Building Component Association (www.sbcsccomponents.com)

MiTek®

400 Sunrise Ave., Suite 270
Roseville, CA 95661
916.755.3571 / MiTek-US.com

Symbols

PLATE LOCATION AND ORIENTATION

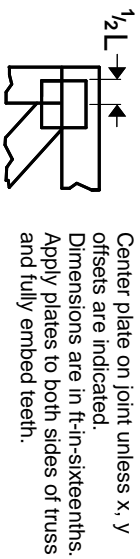

Center plate on joint unless x, y offsets are indicated. Dimensions are in ft-in-sixteenths. Apply plates to both sides of truss and fully embed teeth.

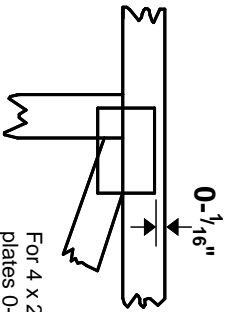

For 4 x 2 orientation, locate plates 0- 1/16\" from outside edge of truss.



This symbol indicates the required direction of slots in connector plates.

* Plate location details available in MITtek software or upon request.

PLATE SIZE

4 X 4

The first dimension is the plate width measured perpendicular to slots. Second dimension is the length parallel to slots.

LATERAL BRACING LOCATION



Indicated by symbol shown and/or by text in the bracing section of the output. Use T or I bracing if indicated.

BEARING

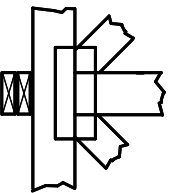

Indicates location where bearings (supports) occur. Icons vary but reaction section indicates joint number/letter where bearings occur. Min size shown is for crushing only.

Industry Standards:

ANSI/TFP1: National Design Specification for Metal Plate Connected Wood Truss Construction.
DSB-22: Design Standard for Bracing.
BCSI: Building Component Safety Information, Guide to Good Practice for Handling, Installing, Restraining & Bracing of Metal Plate Connected Wood Trusses.

Numbering System

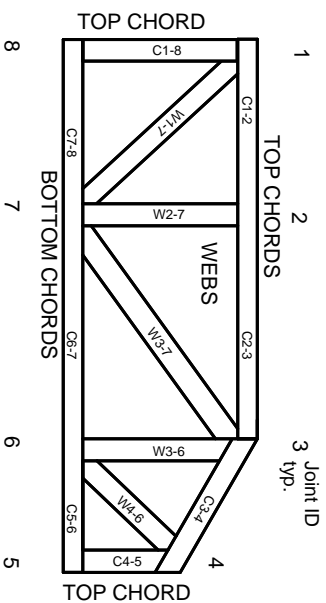

JOINTS ARE GENERALLY NUMBERED/LETTERED CLOCKWISE AROUND THE TRUSS STARTING AT THE JOINT FARTHEST TO THE LEFT.

CHORDS AND WEBS ARE IDENTIFIED BY END JOINT NUMBERS/LETTERS.

Product Code Approvals

ICC-ES Reports:

ESR-1-1988, ESR-2-362, ESR-2-685, ESR-3-282
ESR-4-722, ESL-1-388

Design General Notes

Trusses are designed for wind loads in the plane of the truss unless otherwise shown.

Lumber design values are in accordance with ANSI/TFP 1 section 6.3. These truss designs rely on Lumber values established by others.

© 2023 MITtek® All Rights Reserved

General Safety Notes

Failure to Follow Could Cause Property Damage or Personal Injury

1. Additional stability/bracing for truss system, e.g. diagonal or X-bracing, is always required. See BCSI.
2. Truss bracing must be designed by an engineer. For wide truss spacing, individual lateral braces themselves may require bracing, or alternative Tor I bracing should be considered.
3. Never exceed the design loading shown and never stack materials on inadequately braced trusses.
4. Provide copies of this truss design to the building designer, erection supervisor, property owner and all other interested parties.
5. Cut members to bear tightly against each other.
6. Place plates on each face of truss at each joint and embed fully. Knots and wane at joint locations are regulated by ANSI/TFP 1.
7. Design assumes trusses will be suitably protected from the environment in accord with ANSI/TFP 1.
8. Unless otherwise noted, moisture content of lumber shall not exceed 19% at time of fabrication.
9. Unless expressly noted, this design is not applicable for use with fire retardant, preservative treated, or green lumber.
10. Camber is a non-structural consideration and is the responsibility of truss fabricator. General practice is to camber for dead load deflection.
11. Plate type, size, orientation and location dimensions indicated are minimum plating requirements.
12. Lumber used shall be of the species and size, and in all respects, equal to or better than that specified.
13. Top chords must be sheathed or purlins provided at spacing indicated on design.
14. Bottom chords require lateral bracing at 10 ft. spacing, or less, if no ceiling is installed, unless otherwise noted.
15. Connections not shown are the responsibility of others.
16. Do not cut or alter truss member or plate without prior approval of an engineer.
17. Install and load vertically unless indicated otherwise.
18. Use of green or treated lumber may pose unacceptable environmental, health or performance risks. Consult with project engineer before use.
19. Review all portions of this design (front, back, words and pictures) before use. Reviewing pictures alone is not sufficient.
20. Design assumes manufacture in accordance with ANSI/TFP 1 Quality Criteria.
21. The design does not take into account any dynamic or other loads other than those expressly stated.

MITek®

MITtek Engineering Reference Sheet: Mill-7473 rev. 1/2/2023